

NOTE: FOR MORE DETAILS SEE YOUR V.P. CUSTOMER SERVICE REP.

REVISIONS			
REV.	DESCRIPTION	DATE	APPROVED
A	INITIAL RELEASE	12-03-99	
B	CO 039 Drafting Update	04-10-06	Rick C.

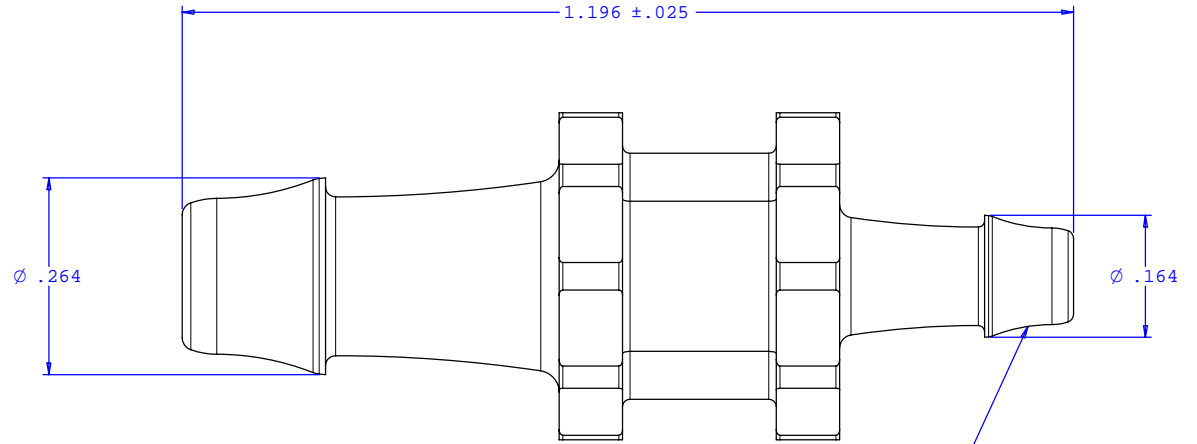

2X INSTRUMENT QUALITY PART. NO PARTING LINE PERMITTED ON THIS CONICAL SURFACE

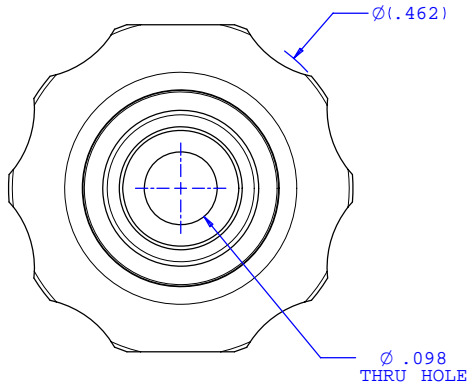
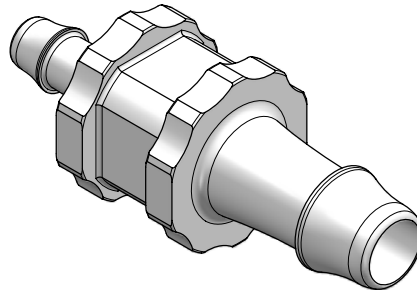

UNLESS OTHERWISE SPECIFIED DIMENSIONS ARE IN INCHES TOLERANCES ARE:		VALUE PLASTICS, INC.	
FRACTIONS ±	DECIMALS .XX ±.01 .XXX ±.005 .XXXX ±.001	ANGULAR ±1°	PART NUMBER: N035/013
DO NOT SCALE DRAWING		DESCRIPTION: Straight Through Reduction Connector with 500 Series Barbs, 3/16" (4.75 mm) and 1/8" (3 mm) ID Tubing	
DRAWN BY: Frank Lombardi	DATE: 01-28-06	SIZE: B	SCALE: NTS
ENGINEER/ MANAGER: Rick Cairns		DRAWING NUMBER: 1008180	REV. B
© 2006 VALUE PLASTICS, INC.			SHEET: 1 OF 1

FOR REFERENCE ONLY