

NOTE: FOR MORE DETAILS SEE YOUR V.P. CUSTOMER SERVICE REP.

REVISIONS			
REV.	DESCRIPTION	DATE	APPROVED
A	INITIAL RELEASE	12-03-99	
B	CO 039 Drafting Update	04-12-06	Rick C.

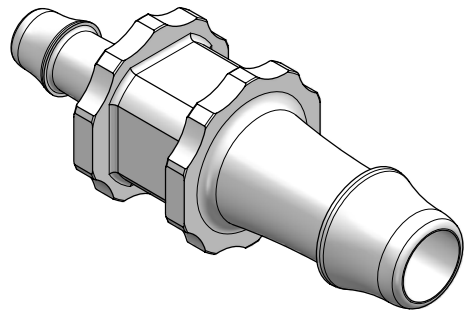
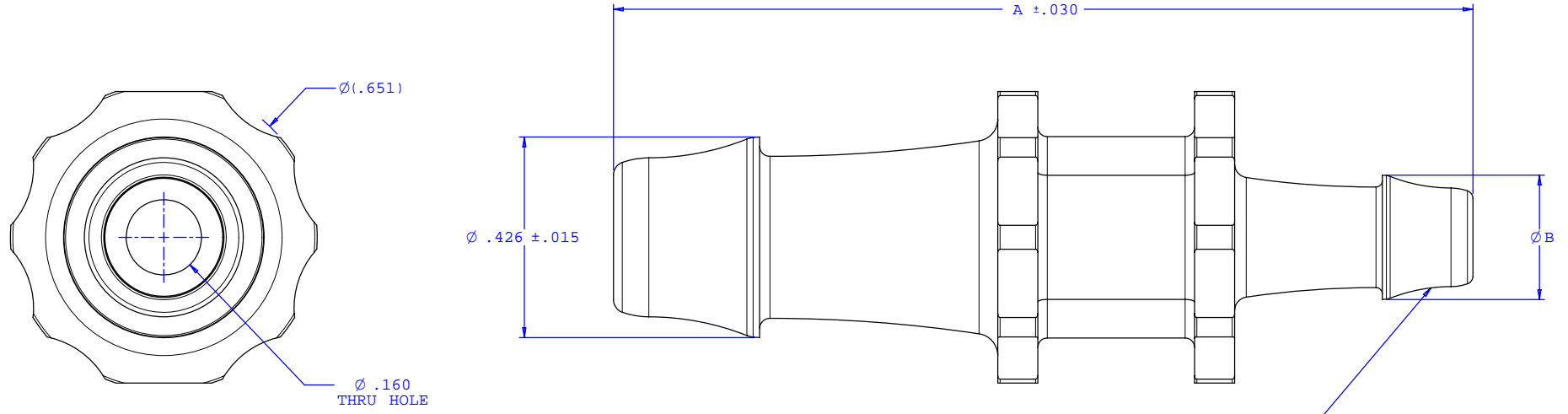

Dimension	Material Specific Tolerances							
	Acetal	Nylon	PP	ABS	PC	PVC	Polysulfone	J1A
A	1.824	1.824	1.824	1.824	1.824	1.824	1.824	1.796
B	.264	.264	.260	.264	.264	.264	.264	.260
C								
D								
E								
F								

UNLESS OTHERWISE SPECIFIED DIMENSIONS ARE IN INCHES TOLERANCES ARE:		VALUE PLASTICS, INC.	
FRACTIONS ±	DECIMALS .XX ±.01 .XXX ±.005 .XXXX ±.001	ANGULAR ±1°	PART NUMBER: N065/035
DO NOT SCALE DRAWING		DESCRIPTION: Straight Through Reduction Connector with 500 Series Barbs, 5/16" (8 mm) and 3/16" (4.75 mm) ID Tubing	
DRAWN BY: Frank Lombardi	DATE: 01-28-06	SIZE: B	SCALE: NTS
ENGINEER/ MANAGER: Rick Cairns		DRAWING NUMBER: 1008183	REV. B
© 2006 VALUE PLASTICS, INC.		SHEET: 1 OF 1	

FOR REFERENCE ONLY