

NOTE: FOR MORE DETAILS SEE YOUR V.P.CUSTOMER SERVICE REP.

REVISIONS			
REV.	DESCRIPTION	DATE	APPROVED
A	INITIAL RELEASE	02-11-03	
B	CO 046 Drafting Update	08-22-06	Rick C.

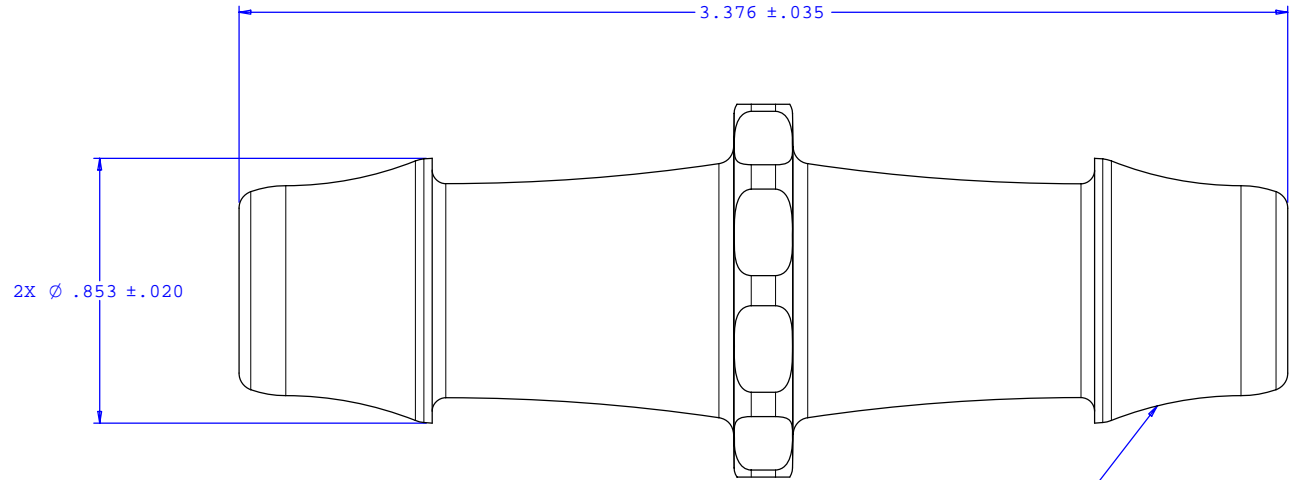

2X INSTRUMENT QUALITY PART. NO PARTING LINE PERMITTED ON THIS CONICAL SURFACE

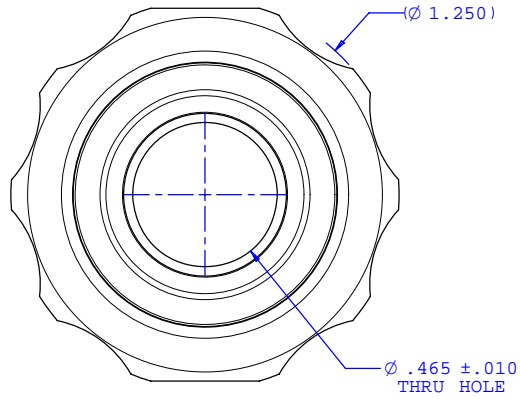
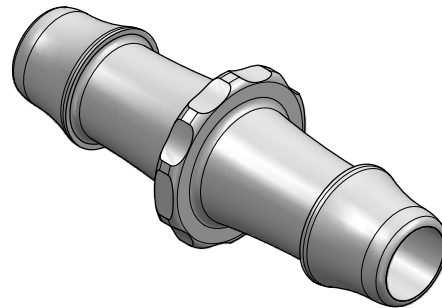

UNLESS OTHERWISE SPECIFIED DIMENSIONS ARE IN INCHES TOLERANCES ARE:		<b>VALUE PLASTICS, INC.</b>	
FRACTIONS ±	DECIMALS .XX ±.01 .XXX ±.005 .XXXX ±.001	ANGULAR ±1°	PART NUMBER: <b>N100</b>
DO NOT SCALE DRAWING		DESCRIPTION: <b>Straight Through Connector with 500 Series Barbs, 3/4" (19 mm) ID Tubing</b>	
DRAWN BY: <b>Frank Lombardi</b>	DATE: <b>06-10-06</b>	SIZE: <b>B</b>	SCALE: <b>NTS</b>
ENGINEER/ MANAGER: <b>Rick Cairns</b>	DRAWING NUMBER: <b>1008987</b>	REV. <b>B</b>	SHEET: <b>1 OF 1</b>
		© 2006 VALUE PLASTICS, INC.	

**FOR REFERENCE ONLY**