

NOTE: FOR MORE DETAILS SEE YOUR V.P. CUSTOMER SERVICE REP.

REVISIONS			
REV.	DESCRIPTION	DATE	APPROVED
A	INITIAL RELEASE	02-11-03	
B	CO 046 Drafting Update	08-22-06	Rick C.

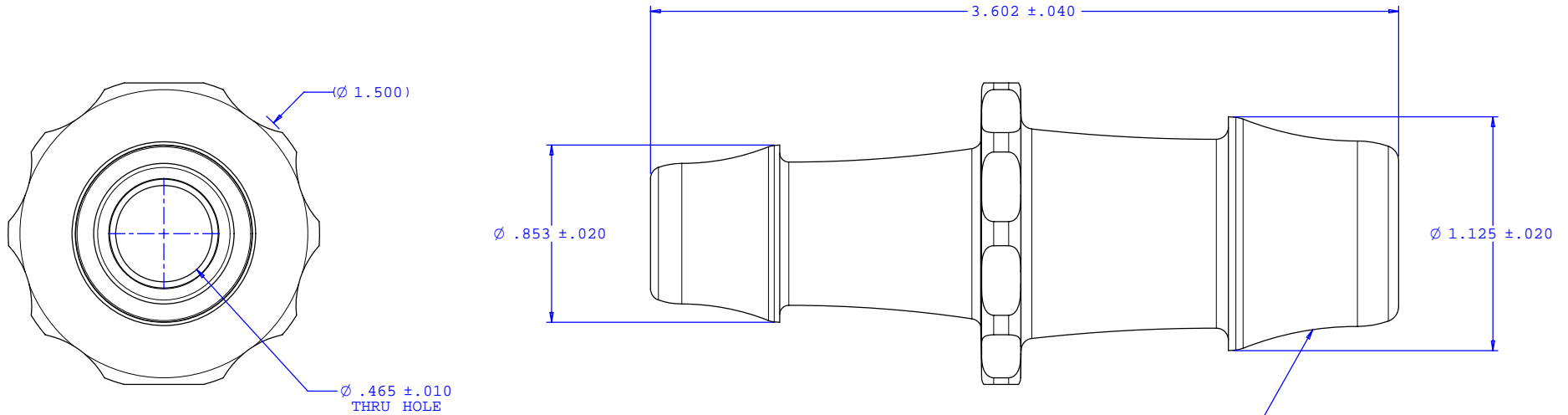

2X INSTRUMENT QUALITY PART. NO
PARTING LINE PERMITTED ON
THIS CONICAL SURFACE

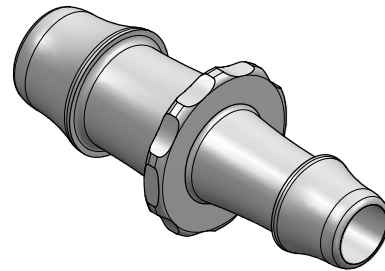

UNLESS OTHERWISE SPECIFIED DIMENSIONS ARE IN INCHES TOLERANCES ARE:		VALUE PLASTICS, INC.	
FRACTIONS ±	DECIMALS .XX ±.01 .XXX ±.005 .XXXX ±.001	ANGULAR ±1°	PART NUMBER: N110/100
DO NOT SCALE DRAWING		DESCRIPTION: Straight Through Reduction Connector With 500 Series Barbs, 1" (25.5 mm) and 3/4" (19 mm) ID Tubing	
DRAWN BY: Frank Lombardi	DATE: 06-10-06	SIZE: B	SCALE: NTS
Engineer/Manager: Rick Cairns		DRAWING NUMBER: 1008978	REV. B
© 2006 VALUE PLASTICS, INC.			SHEET: 1 OF 1

FOR REFERENCE ONLY