

NOTES: FOR ADDITIONAL DETAILS, PLEASE CONTACT VP CUSTOMER SERVICE
 DIMENSIONS MARKED  ARE CONTROL DIMENSIONS

REVISIONS			
REV.	DESCRIPTION	DATE	APPROVED
A	INITIAL RELEASE	04-07-14	HL

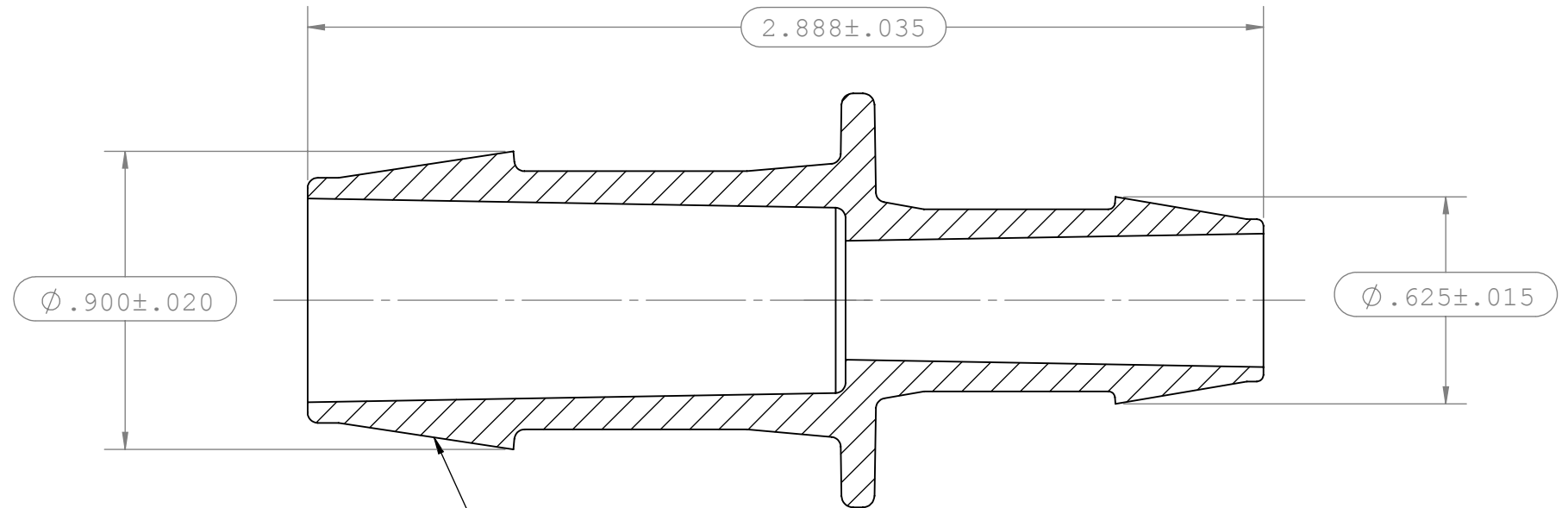
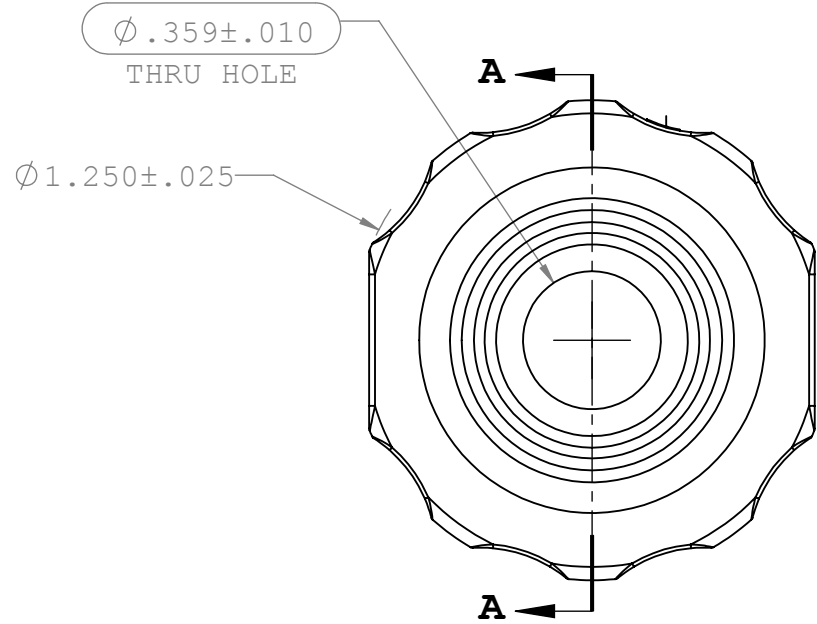

SECTION A-A

2X INSTRUMENT QUALITY PART.
 NO PARTING LINE PERMITTED ON
 THIS CONICAL SURFACE.

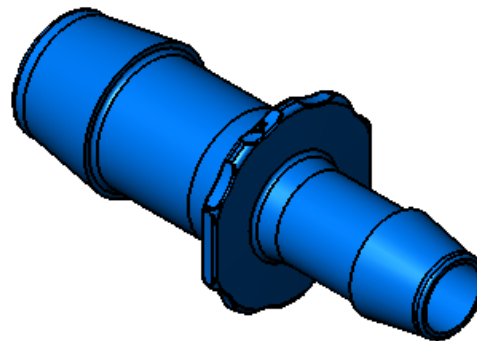

UNLESS OTHERWISE SPECIFIED DIMENSIONS ARE IN INCHES TOLERANCES ARE:		VALUE PLASTICS, INC			
FRACTIONS DECIMAL ANGULAR \pm .XX $\pm .01$ $\pm 1^\circ$.XXX $\pm .005$.XXXX $\pm .001$		PART NUMBER: N6100-680			
DO NOT SCALE DRAWING		DESCRIPTION: Straight Through Reduction Tube Fitting with 600 Series Barbs, 3/4" (19 mm) and 1/2" (12.7 mm) ID Tubing			
DRAWN BY: Jonathan Mayer	DATE: 4/17/2014	SIZE: B	SCALE: NTS	VER: 	DWG. NO. 1030117
MANAGER: Huadong L.		© 2011 VALUE PLASTICS, INC			REV A
				SHEET: 1 OF 1	

FOR REFERENCE ONLY