

NOTE: FOR MORE DETAILS SEE YOUR V.P. CUSTOMER SERVICE REP.

REVISIONS			
REV.	DESCRIPTION	DATE	APPROVED
A	INITIAL RELEASE	04-22-05	RICK C.

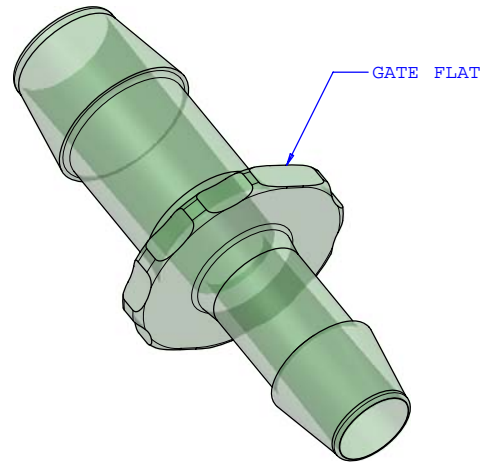
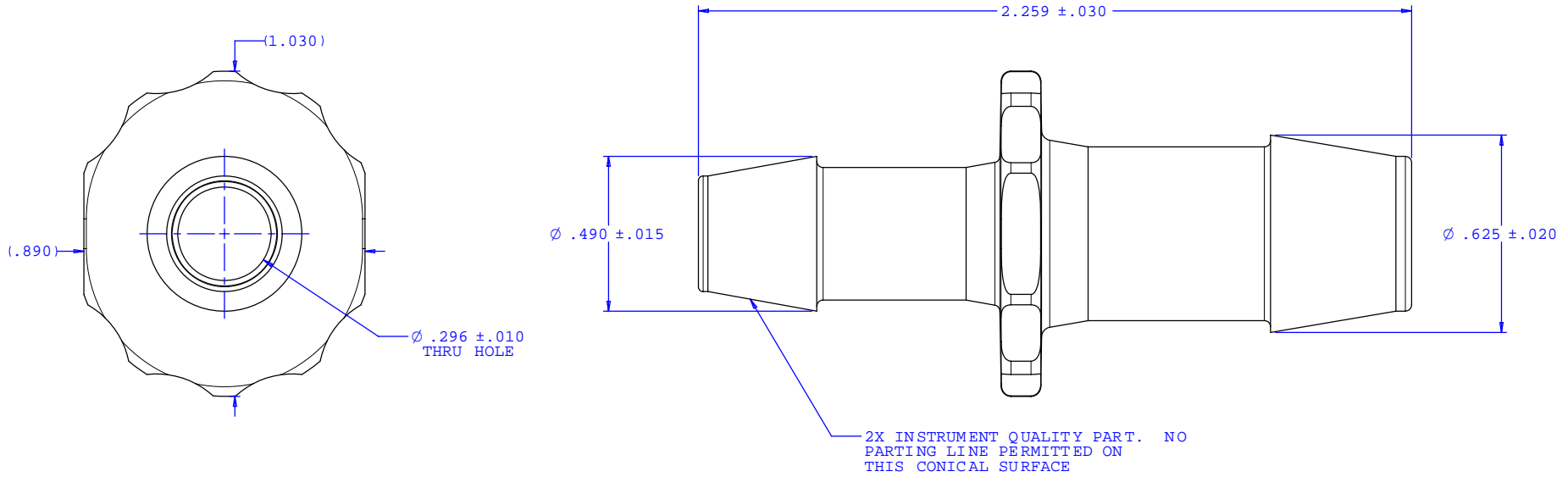

UNLESS OTHERWISE SPECIFIED DIMENSIONS ARE IN INCHES TOLERANCES ARE:		VALUE PLASTICS, INC.	
FRACTIONS ±	DECIMALS .XX ±.01 .XXX ±.005 .XXXX ±.001	ANGULAR ±1°	PART NUMBER: N680/670
DO NOT SCALE DRAWING		DESCRIPTION: Straight Thru Reduction Connector with 600 Series Barbs, 1/2" (12.5 mm) and 3/8" (9.5 mm) ID Tubing	
DRAWN BY: Frank Lombardi 4-19-05	DATE:	SIZE: B	SCALE: NTS
Engineer/Manager: Rick Cairns		DRAWING NUMBER: 1006294	REV. A
© 2005 VALUE PLASTICS, INC.			SHEET: 1 OF 1

FOR REFERENCE ONLY