

NOTES: FOR ADDITIONAL DETAILS, PLEASE CONTACT VP CUSTOMER SERVICE

1. DIMENSIONS MARKED  $\varnothing$  ARE CONTROL DIMENSIONS
2. USE CG101 INSPECTION GAGE FOR TAPER
3. USE S69 INSPECTION GAGE FOR THREADS

REVISIONS			
REV.	DESCRIPTION	DATE	APPROVED
A	INITIAL RELEASE	12-05-16	FJL

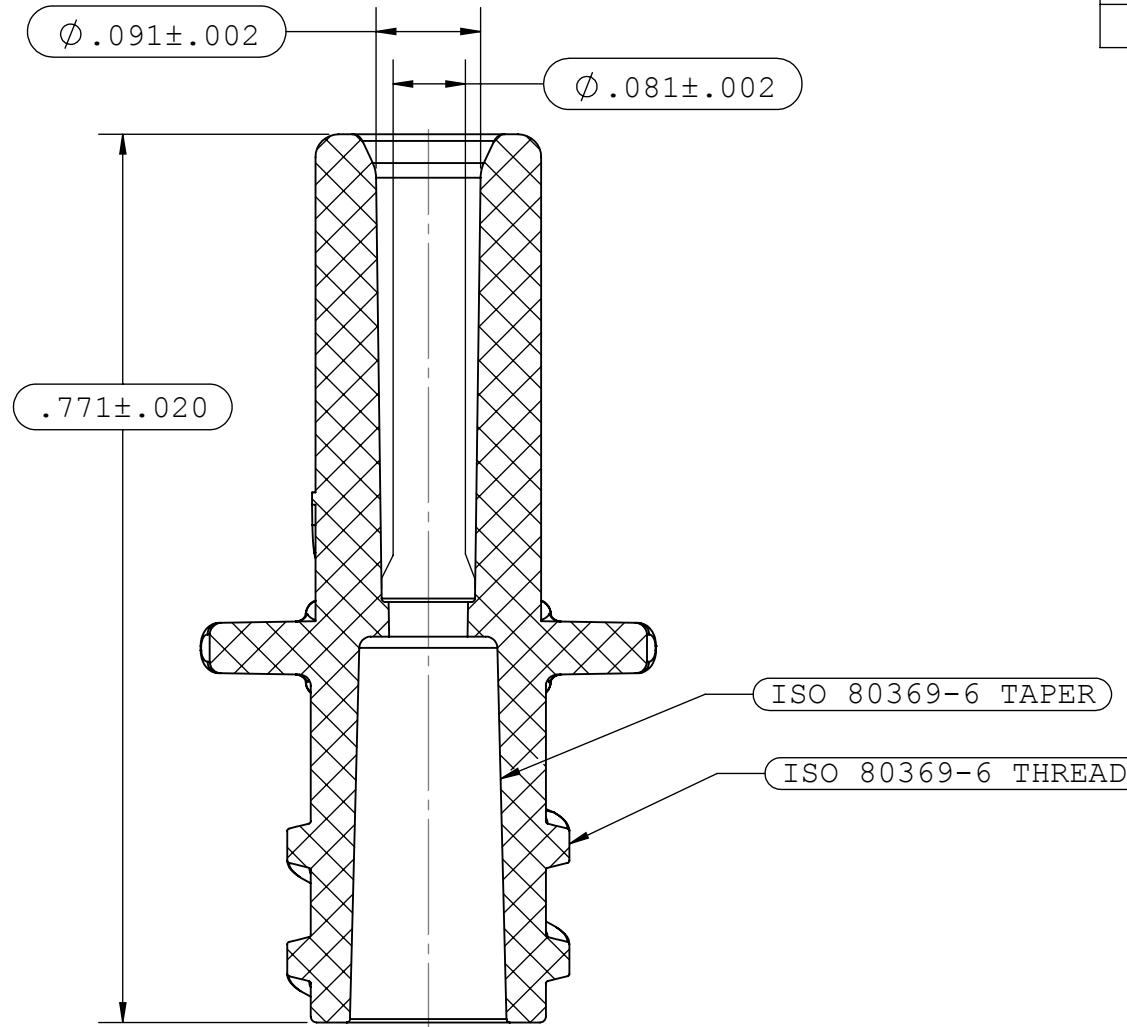
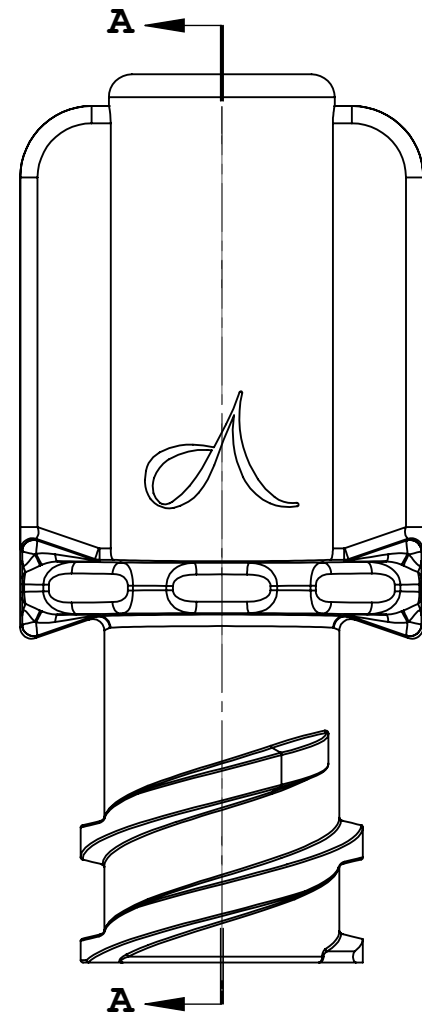

SECTION A-A

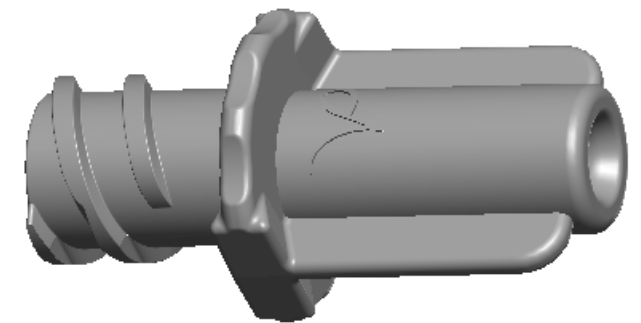
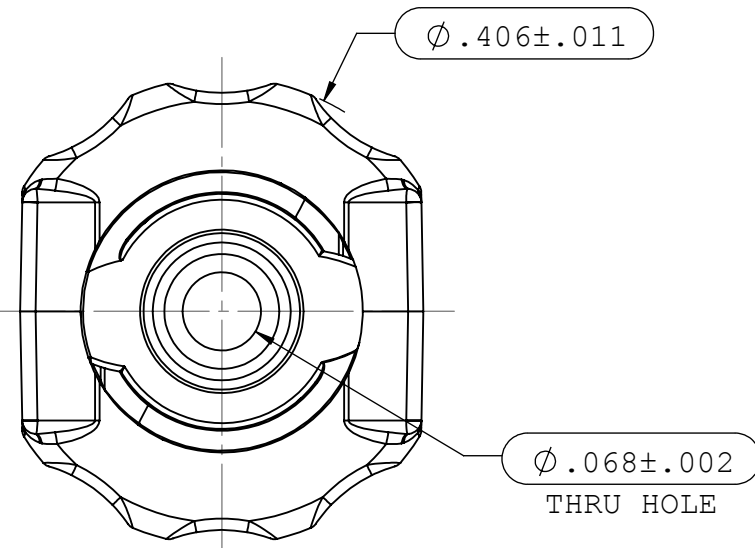

UNLESS OTHERWISE SPECIFIED DIMENSIONS ARE IN INCHES TOLERANCES ARE:		<b>VALUE PLASTICS, INC</b>			
FRACTIONS    DECIMAL    ANGULAR $\pm$ .XX $\pm .01$ $\pm 1^\circ$ .XXX $\pm .005$ .XXXX $\pm .001$		PART NUMBER: NEFE21			
DO NOT SCALE DRAWING		DESCRIPTION: Neuraxial Female Connector with 2.1mm Tubing Bond-in Pocket			
DRAWN BY: Pete L.	DATE: 12/5/2016	SIZE: <b>B</b>	SCALE: NTS	VER: 	DWG. NO. 1041547
MANAGER: Frank.Lombardi		© 2014 VALUE PLASTICS, INC		SHEET: 1 OF 1	REV A

**FOR REFERENCE ONLY**