

NOTES: FOR ADDITIONAL DETAILS, PLEASE CONTACT VP CUSTOMER SERVICE

1. DIMENSIONS MARKED  $\phi$  ARE CONTROL DIMENSIONS
2. MUST USE CG102 INSPECTION GAGE FOR TAPER
3. MUST USE S67 INSPECTION GAGE FOR THREADS

REVISIONS			
REV.	DESCRIPTION	DATE	APPROVED
A	INITIAL RELEASE	04-20-16	FJL

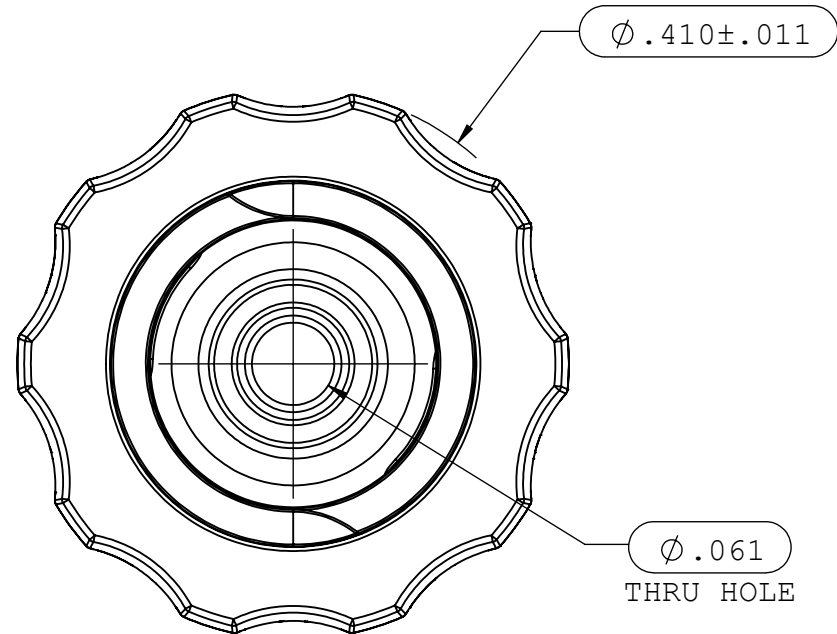
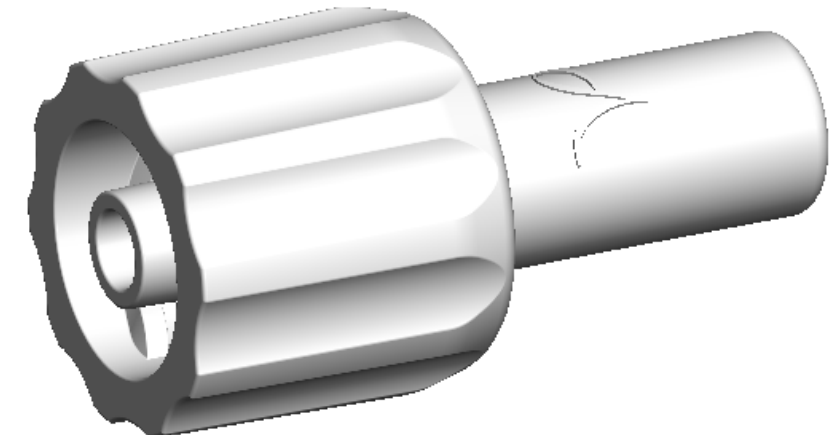
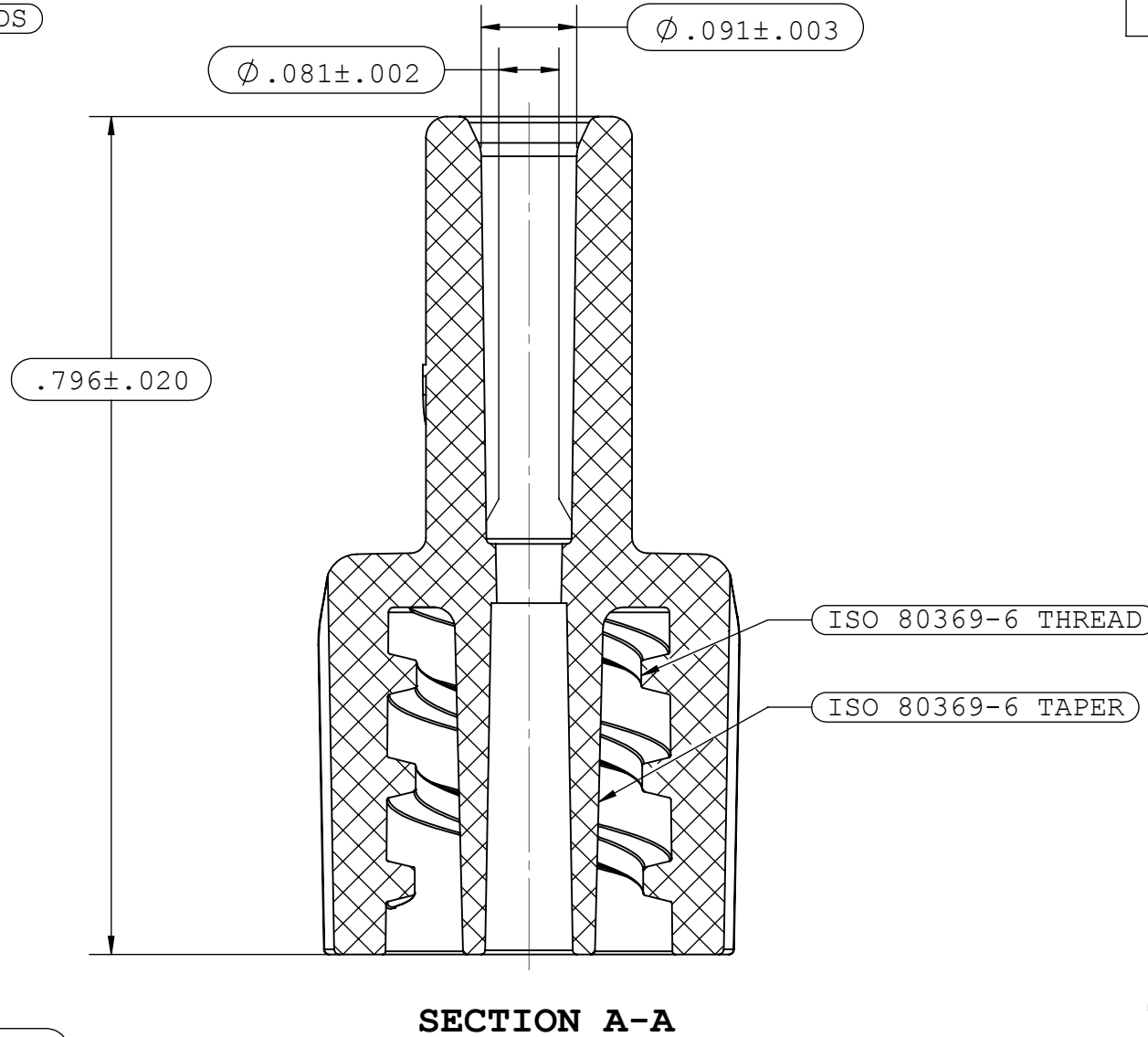
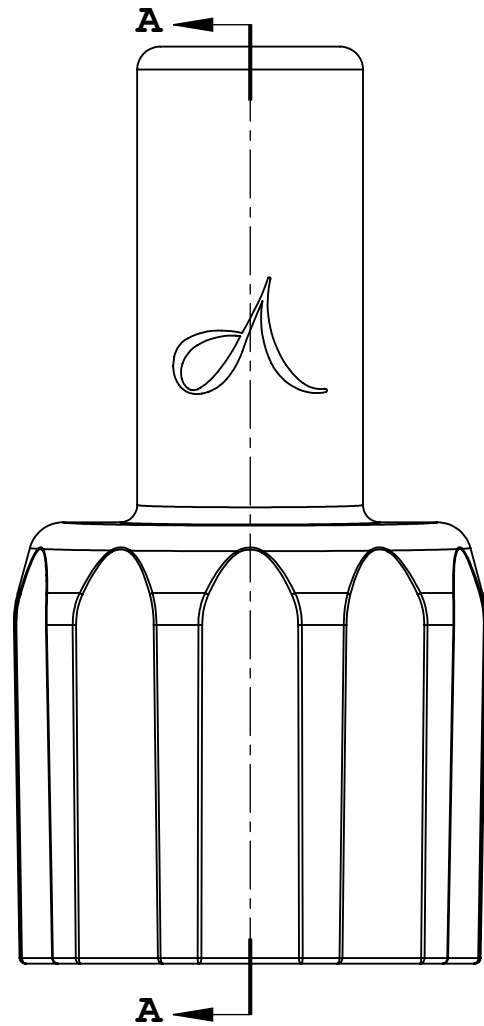

UNLESS OTHERWISE SPECIFIED DIMENSIONS ARE IN INCHES TOLERANCES ARE:		<b>VALUE PLASTICS, INC</b>			
FRACTIONS	DECIMAL				
$\pm$	.XX $\pm .01$	$\pm 1^\circ$	DESCRIPTION:	Neuraxial Male Connector with 2.1mm Tubing Bond-in Pocket, Natural Acrylic	
	.XXX $\pm .005$		SIZE:	B	
	.XXXX $\pm .001$		SCALE:	NTS	
DO NOT SCALE DRAWING			VER:		
MANAGER:	DATE:	DWG. NO.	REV:	A	
Frank.Lombardi	4/20/2016	1039808	SHEET: 1 OF 1		
© 2014 VALUE PLASTICS, INC					

**FOR REFERENCE ONLY**