

NOTES: 1.FOR ADDITIONAL DETAILS, PLEASE CONTACT VP NEW PRODUCT DEVELOPMENT  
 2.DIMENSIONS MARKED  $\text{\textcircled{\hspace{1cm}}}$  ARE CONTROL DIMENSIONS  
 3.VERIFY THREAD USING 1/4-28" UNF-2A PD .2258 GO THREAD GAUGE

REVISIONS			
REV.	DESCRIPTION	DATE	APPROVED
A	INITIAL RELEASE	06-19-98	
B	CO 031 DRAFTING UPDATE	01-17-06	Rick C.
C	ECO 285 ECO 358	02-08-17	FJL

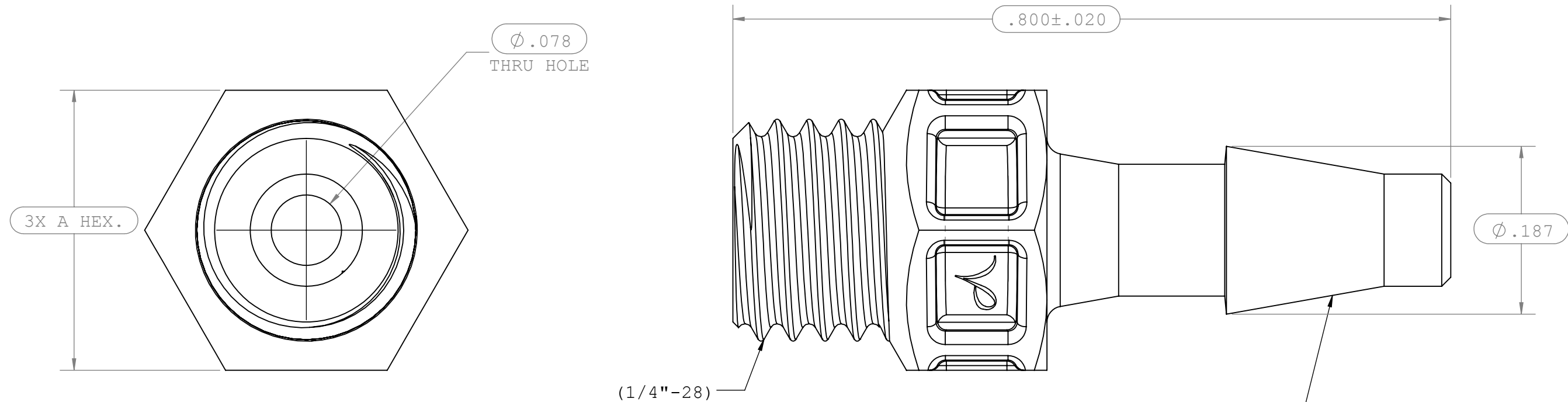

INSTRUMENT QUALITY PART.  
 NO PARTING LINE PERMITTED  
 ON THIS CONICAL SURFACE.

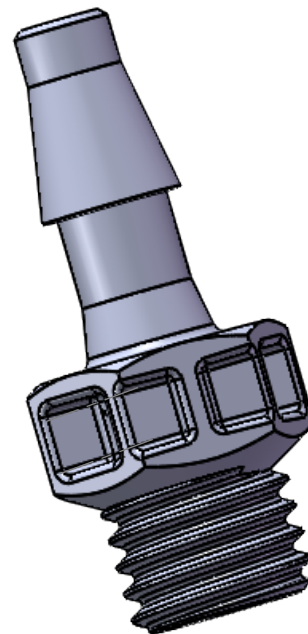

Dimension	Material Specific Tolerances							
	Acetal	Nylon	PP	ABS	PC	PVC	Polysulfone	Kynar
A	.312	.312	.312	.312	.312	.312	.312	.307
B								
C								
D								
E								
F								

UNLESS OTHERWISE SPECIFIED DIMENSIONS ARE IN INCHES TOLERANCES ARE:				<b>VALUE PLASTICS, INC</b>			
FRACTIONS		DECIMAL		ANGULAR		PART NUMBER:	
± .XX		± .01		± 1°		S30	
± .XXX		± .005				DESCRIPTION: 1/4-28 UNF Thread with 5/16" Hex to Classic Series Barb, 1/8" (3.2 mm) ID Tubing	
± .XXXX		± .001				REV: C	
DO NOT SCALE DRAWING							
DRAWN BY: shannond		DATE: 3/1/2017		SIZE: <b>B</b> NTS		VER: 1007772	
MANAGER: huadong.lou				© 2011 VALUE PLASTICS, INC		SHEET: 1 OF 1	

**FOR REFERENCE ONLY**