

NOTES: FOR ADDITIONAL DETAILS, PLEASE CONTACT VP CUSTOMER SERVICE
 DIMENSIONS MARKED \varnothing ARE CONTROL DIMENSIONS
 ALL INTERIOR SURFACES HAVE A 15 Ra MICROINCH SURFACE FINISH OR FINER
 ALL EXTERIOR SURFACES HAVE A 20 Ra MICROINCH SURFACE FINISH OR FINER

REVISIONS			
REV.	DESCRIPTION	DATE	APPROVED
A	INITIAL RELEASE	01/09/12	S.N.R

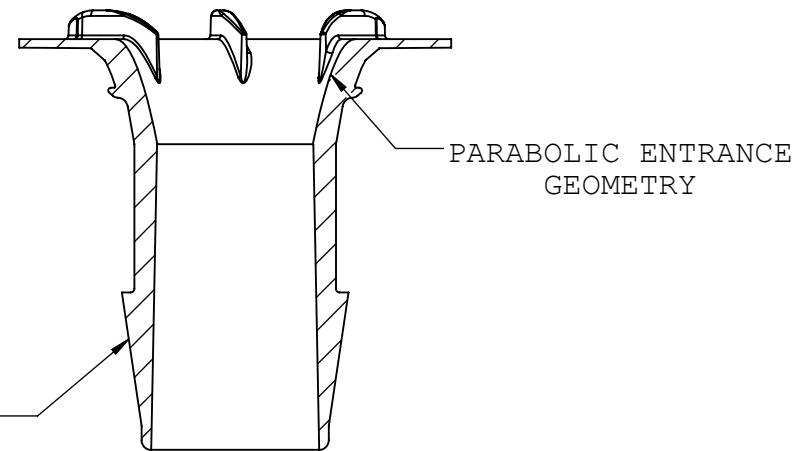
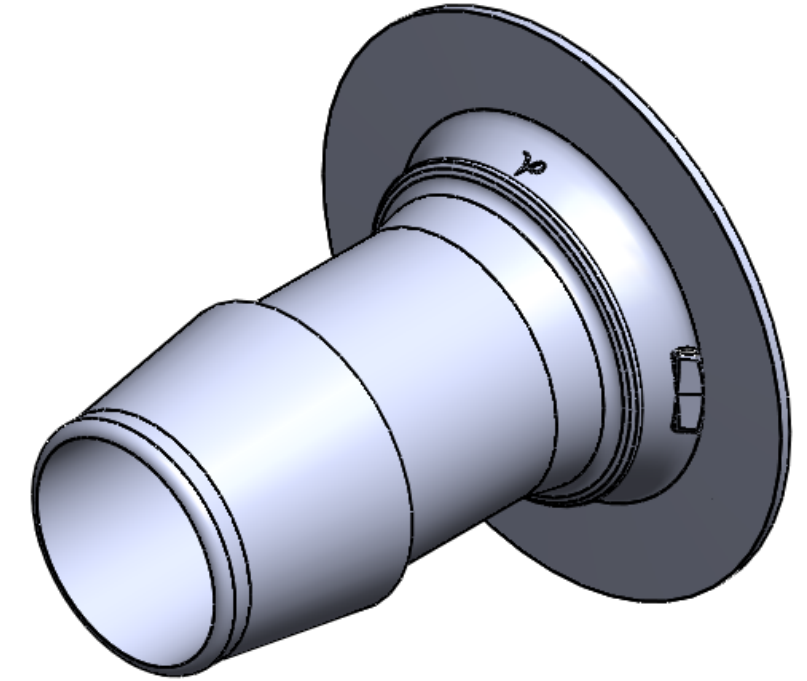
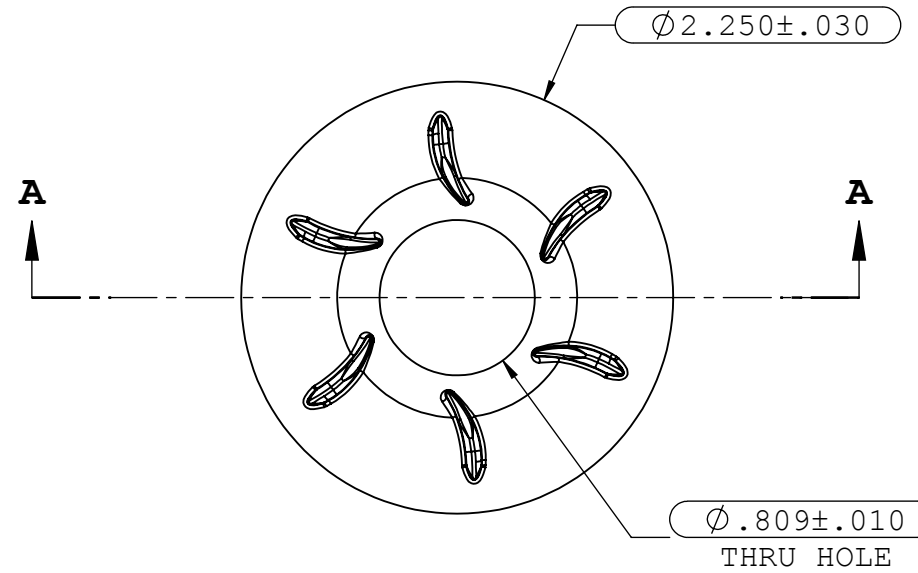
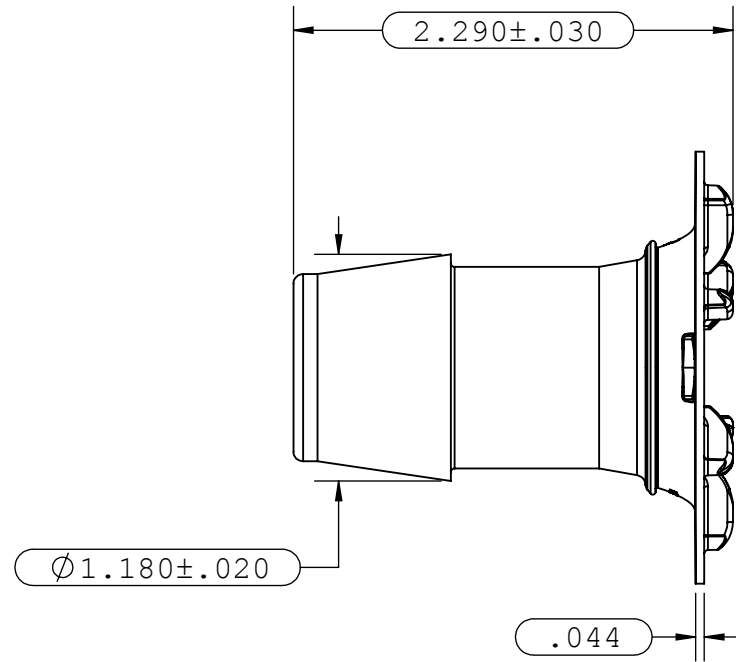

INSTRUMENT QUALITY SURFACE,
NO PARTING LINE PERMITTED

SECTION A-A

UNLESS OTHERWISE SPECIFIED DIMENSIONS ARE IN INCHES TOLERANCES ARE:		VALUE PLASTICS, INC			
FRACTIONS DECIMAL ANGULAR ± .XX ±.01 ± 1° .XXX ±.005 .XXXX ±.001		PART NUMBER: SFBP6110			
DO NOT SCALE DRAWING		DESCRIPTION: SANITARY FITTING, BAG PORT 600 SERIES BARB, 1" (25.4mm) I.D. TUBING			
DRAWN BY: kyles	DATE: 1/10/2012	SIZE: B	SCALE: NTS	VER: 	DWG. NO. 1022168
NEW PRODUCT DEVELOPMENT MGR: R. Narayanan		© 2010 VALUE PLASTICS, INC			REV A
				SHEET: 1 OF 1	

FOR REFERENCE ONLY