

NOTES: FOR ADDITIONAL DETAILS, PLEASE CONTACT VP CUSTOMER SERVICE
 DIMENSIONS MARKED  ARE CONTROL DIMENSIONS

REVISIONS			
REV.	DESCRIPTION	DATE	APPROVED
A	INITIAL RELEASE	05-19-14	H.L.

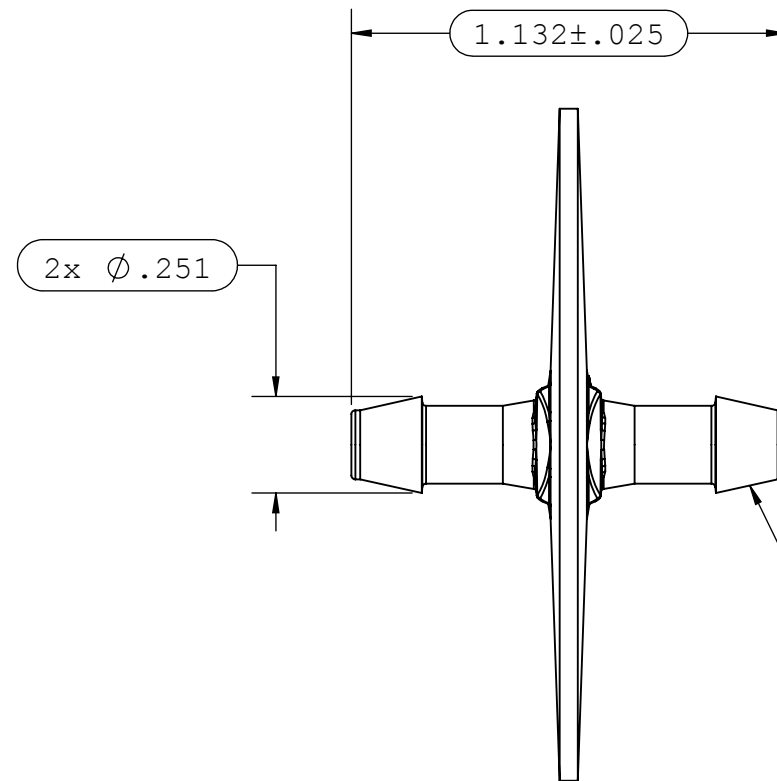

2X INSTRUMENT QUALITY PART.
 NO PARTING LINES PERMITTED
 ON THIS SEALING SURFACE.

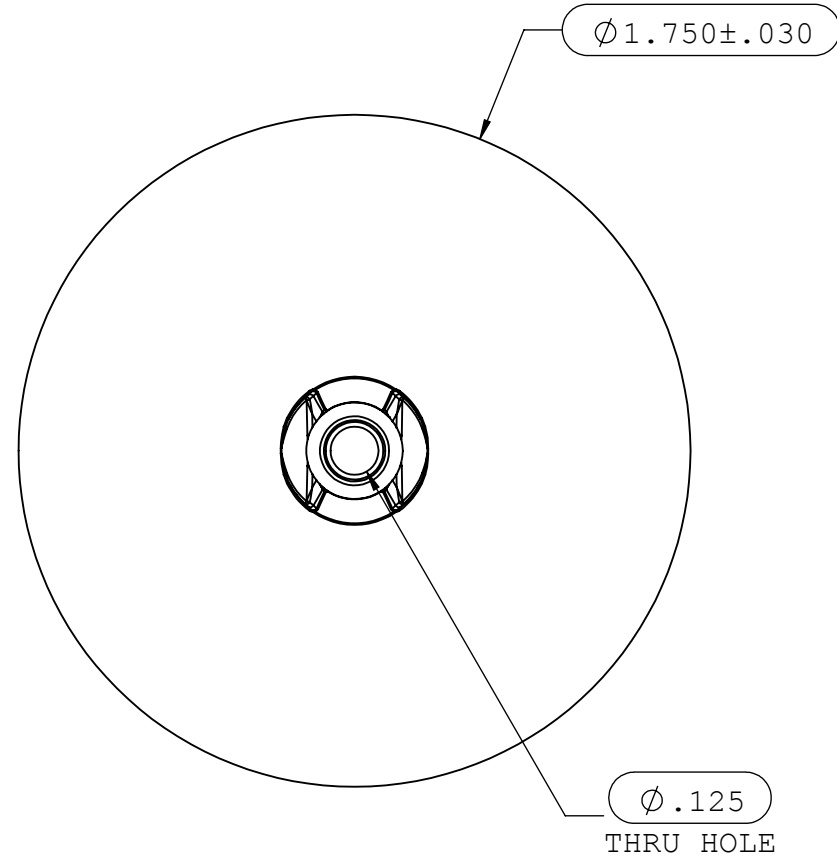
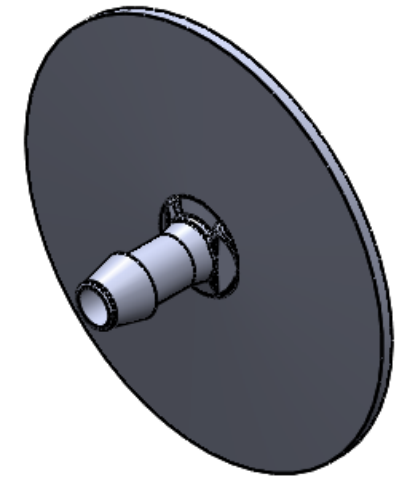

UNLESS OTHERWISE SPECIFIED DIMENSIONS ARE IN INCHES TOLERANCES ARE:		VALUE PLASTICS, INC			
FRACTIONS DECIMAL ANGULAR \pm .XX \pm .01 \pm 1° .XXX \pm .005 .XXXX \pm .001 DO NOT SCALE DRAWING		PART NUMBER: SFBP635_635			
DESCRIPTION: Dip Tube (Opposable Barbs) with two 600 Series Barbs, 3/16" (4.8 mm) Tubing ID		SIZE:	SCALE:	VER:	DWG. NO.
DRAWN BY: kyles	DATE: 6/10/2014	B	NTS		1030644
MANAGER: RaviN		© 2011 VALUE PLASTICS, INC			REV A
				SHEET:	1 OF 1

FOR REFERENCE ONLY