

- NOTES: 1. FOR ADDITIONAL DETAILS, PLEASE CONTACT VP PRODUCT DEVELOPMENT
 2. DIMENSIONS MARKED (---) ARE CONTROL DIMENSIONS
 3. FERRULE END CAPS ARE DESIGNED TO WORK WITH COMMON COMPONENTS USED IN BIOPROCESSING INDUSTRY

REVISIONS			
REV.	DESCRIPTION	DATE	APPROVED
A	INITIAL RELEASE	03-29-19	FJL
B	ECO 1080165	05-15-19	FJL

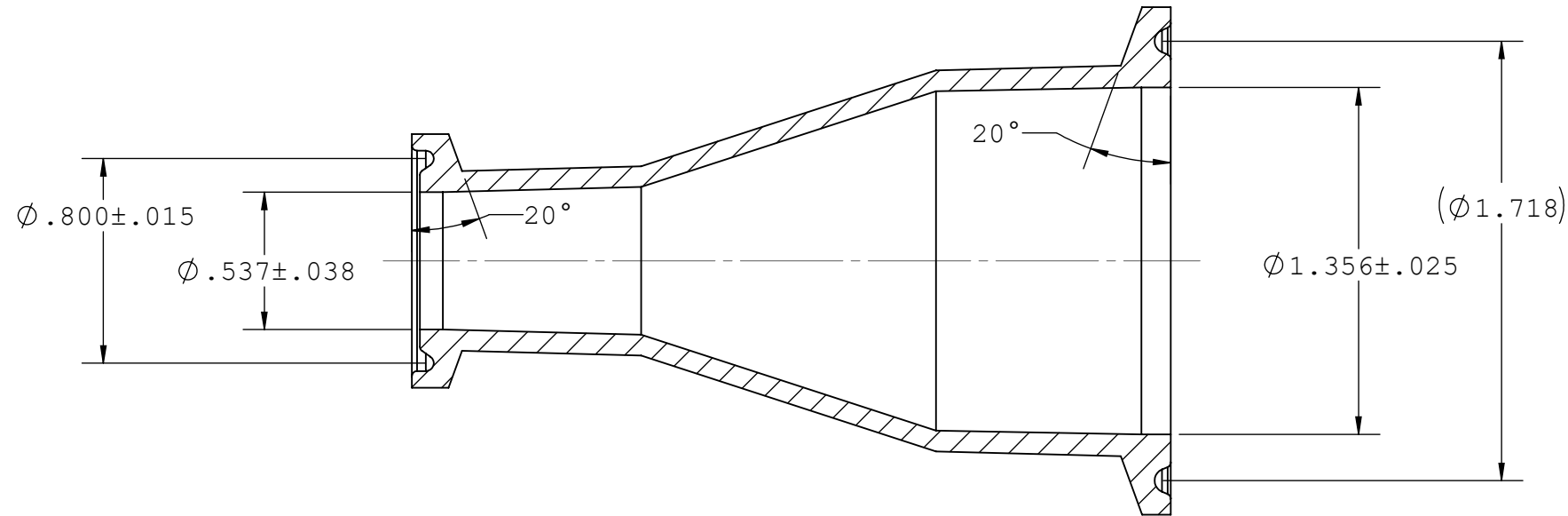

SECTION A-A

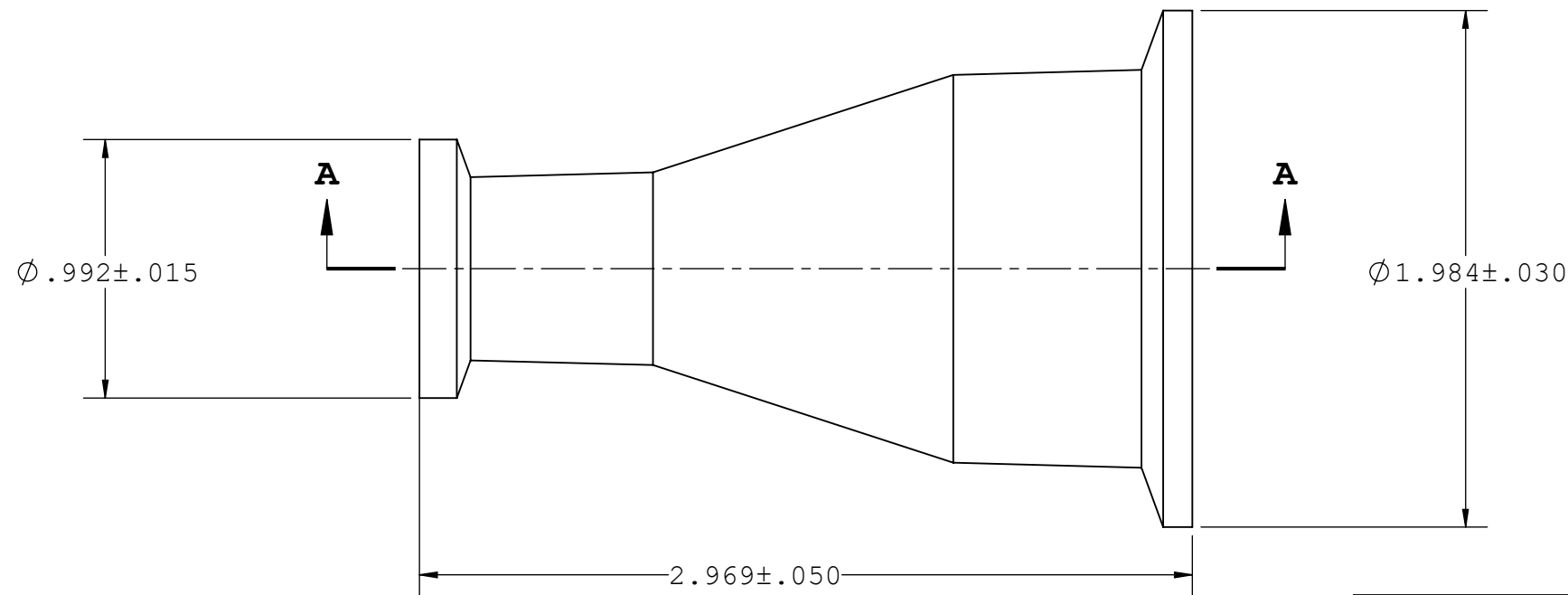
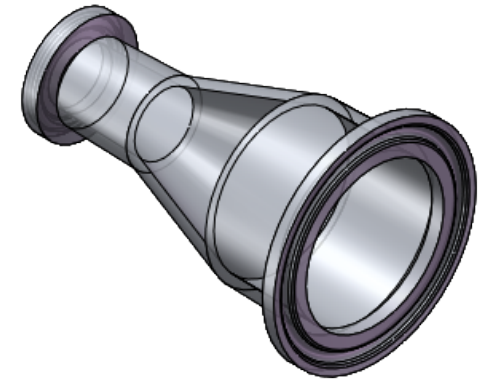

UNLESS OTHERWISE SPECIFIED DIMENSIONS ARE IN INCHES TOLERANCES ARE:		VALUE PLASTICS, INC			
FRACTIONS DECIMAL ANGULAR ± .XX ±.01 ± 1° .XXX ±.005 .XXXX ±.001		PART NUMBER: SFM150-SFM075			
DO NOT SCALE DRAWING		DESCRIPTION: Sanitary Fitting, Concentric Reducer 1-1/2" TC x 3/4" Mini TC			
DRAWN BY: Frank.Lombardi	DATE: 5/15/2019	SIZE: B	SCALE: NTS	VER: 	DWG. NO. 1078642
NEW PRODUCT DEVELOPMENT MGR: Doug Kimmel		© 2007 VALUE PLASTICS, INC			REV B
				SHEET: 1 OF 1	

FOR REFERENCE ONLY