

SECTION A-A

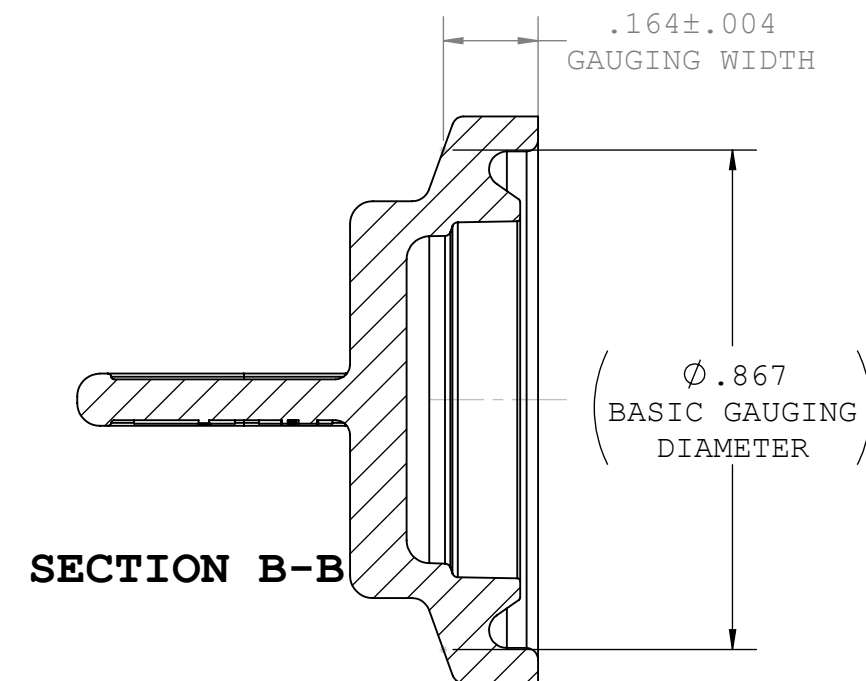

REVISIONS			
REV.	DESCRIPTION	DATE	APPROVED
A	INITIAL RELEASE	12-03-08	S.N.R.
B	ADDED MATERIAL SPECIFIC DIMENSIONS PER ECO 113	03-02-09	S.N.R
C	ECO 248	10-11-13	S.N.R
D	ECO 313 RevA	04-05-16	FJL
E	ECO 313 Rev B	03-08-17	FJL

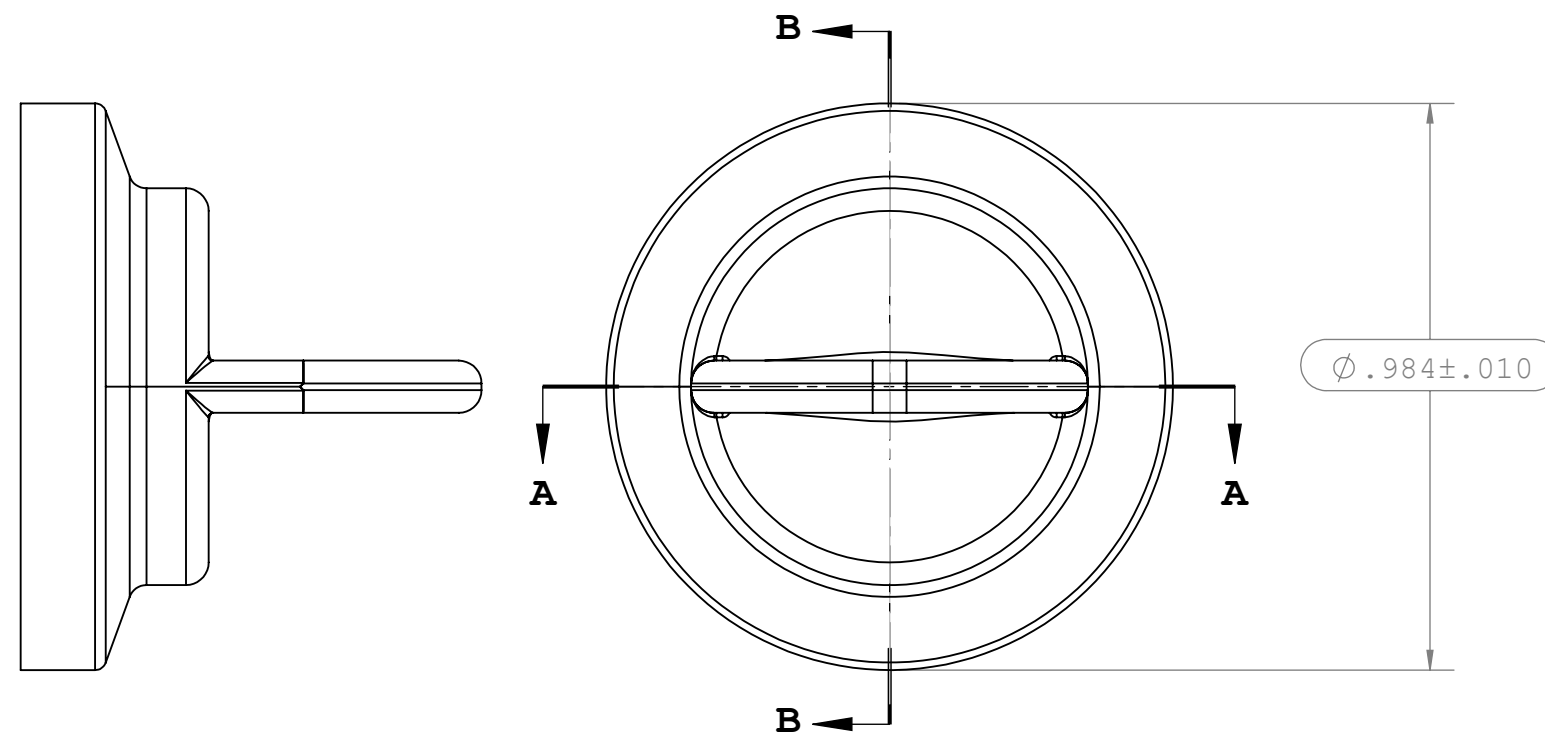

SECTION B-B

- NOTES:
- FOR ADDITIONAL DETAILS, PLEASE CONTACT VP PRODUCT DEVELOPMENT
 - DIMENSIONS MARKED ϕ ARE CONTROL DIMENSIONS
 - ALL EXTERIOR SURFACES HAVE A MAXIMUM OF 20 Ra MICROINCH SURFACE FINISH
 - ALL INTERIOR SURFACES HAVE A MAXIMUM OF 15 Ra MICROINCH SURFACE FINISH
 - VALUE PLASTICS SFMN SERIES FERRULES ARE DESIGNED TO COMPLY WITH ASME BPE-2014 TABLE DT-7-1 HYGIENIC CLAMP FERRULE STANDARD DIMENSIONS & TOLERANCES; DT-9.3-1 HYGIENIC CLAMP FERRULE: DESIGN CRITERIA. REF PM-4.6.1.2. PERFORMANCE NOTE.
 - ALL INTERIOR AND EXTERIOR SURFACE FINISHES COMPLY WITH ASME BPE-2016 TABLE SF-3.4-1 SFP2 Ra Readings for Polymeric Product Contact Surfaces

UNLESS OTHERWISE SPECIFIED DIMENSIONS ARE IN INCHES TOLERANCES ARE:		VALUE PLASTICS, INC			
FRACTIONS	DECIMAL				
± .XX	± .01	± 1°	DESCRIPTION:	Sanitary Fitting, Cap With 3/4" Mini Flange	
± .XXX	± .005		DRAWN BY:	Pete L.	
± .XXXX	± .001		DATE:	3/8/2017	
DO NOT SCALE DRAWING			SIZE:	B	
			SCALE:	NTS	
			VER:		
			DWG. NO.:	1013818	
			REV:	E	
NEW PRODUCT DEVELOPMENT MGR:				R. Narayanan	
© 2007 VALUE PLASTICS, INC				SHEET: 1 OF 1	

FOR REFERENCE ONLY