

- NOTES:
- FOR ADDITIONAL DETAILS, PLEASE CONTACT VP PRODUCT DEVELOPMENT
  - DIMENSIONS MARKED (---) ARE CONTROL DIMENSIONS
  - ALL EXTERIOR SURFACES HAVE A MAXIMUM OF 20 Ra MICROINCH SURFACE FINISH
  - ALL INTERIOR SURFACES HAVE A MAXIMUM OF 15 Ra MICROINCH SURFACE FINISH
  - VALUE PLASTICS SFMX SERIES FERRULES ARE DESIGNED TO COMPLY WITH ASME BPE-2014 TABLE DT-7-1 HYGIENIC CLAMP FERRULE STANDARD DIMENSIONS & TOLERANCES; DT-9.3-1 HYGIENIC CLAMP FERRULE: DESIGN CRITERIA. REF PM-4.6.1.2. PERFORMANCE NOTE.
  - ALL INTERIOR AND EXTERIOR SURFACE FINISHES COMPLY WITH ASME BPE-2014 TABLE SF-3.4-1 SFP2 Ra Readings for Polymeric Product Contact Surfaces

REVISIONS			
REV.	DESCRIPTION	DATE	APPROVED
A	INITIAL CONCEPT	09-17-16	H.L

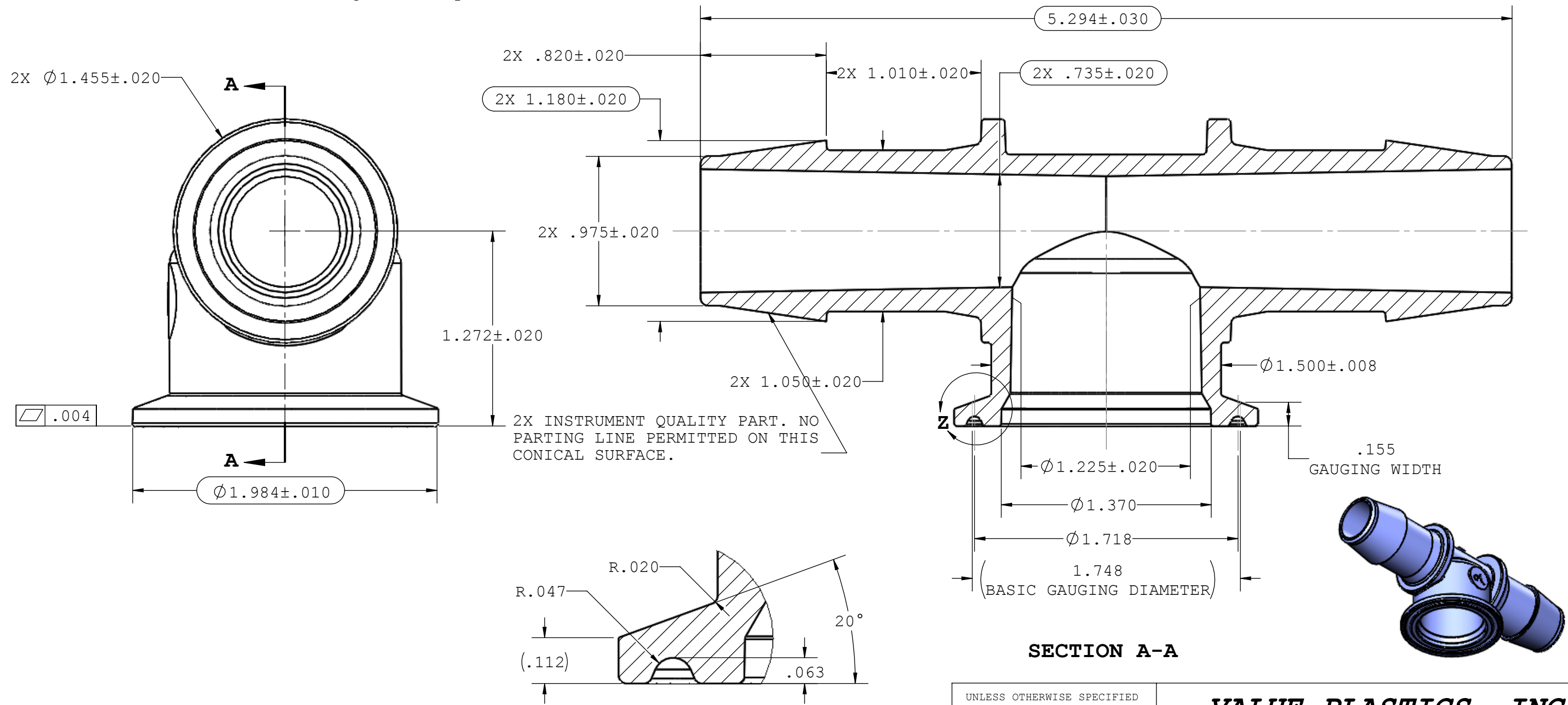

SECTION A-A

DETAIL Z

UNLESS OTHERWISE SPECIFIED DIMENSIONS ARE IN INCHES TOLERANCES ARE:		<b>VALUE PLASTICS, INC</b>			
FRACTIONS	DECIMAL				
±	.XX ±.01	± 1°			
	.XXX ±.005				
	.XXXX ±.001				
DO NOT SCALE DRAWING					
DRAWN BY: Frank.Lombardi		DATE: 11/2/2016		PART NUMBER: SFMXT6110	
MANAGER: Huadong Lou		SIZE: <b>B</b>	SCALE: NTS	VER: 1038045	DWG. NO. 1038045
© 2014 VALUE PLASTICS, INC				REVISION: A	
				SHEET: 1 OF 1	

FOR REFERENCE ONLY