

NOTES: FOR MORE DETAILED DRAWING SEE V.P.TOOLING STANDARDS  
 DIMENSIONS MARKED  OR  ARE CONTROL DIMENSIONS

REVISIONS			
REV.	DESCRIPTION	DATE	APPROVED
A	INITIAL RELEASE	07-29-08	S.N.R

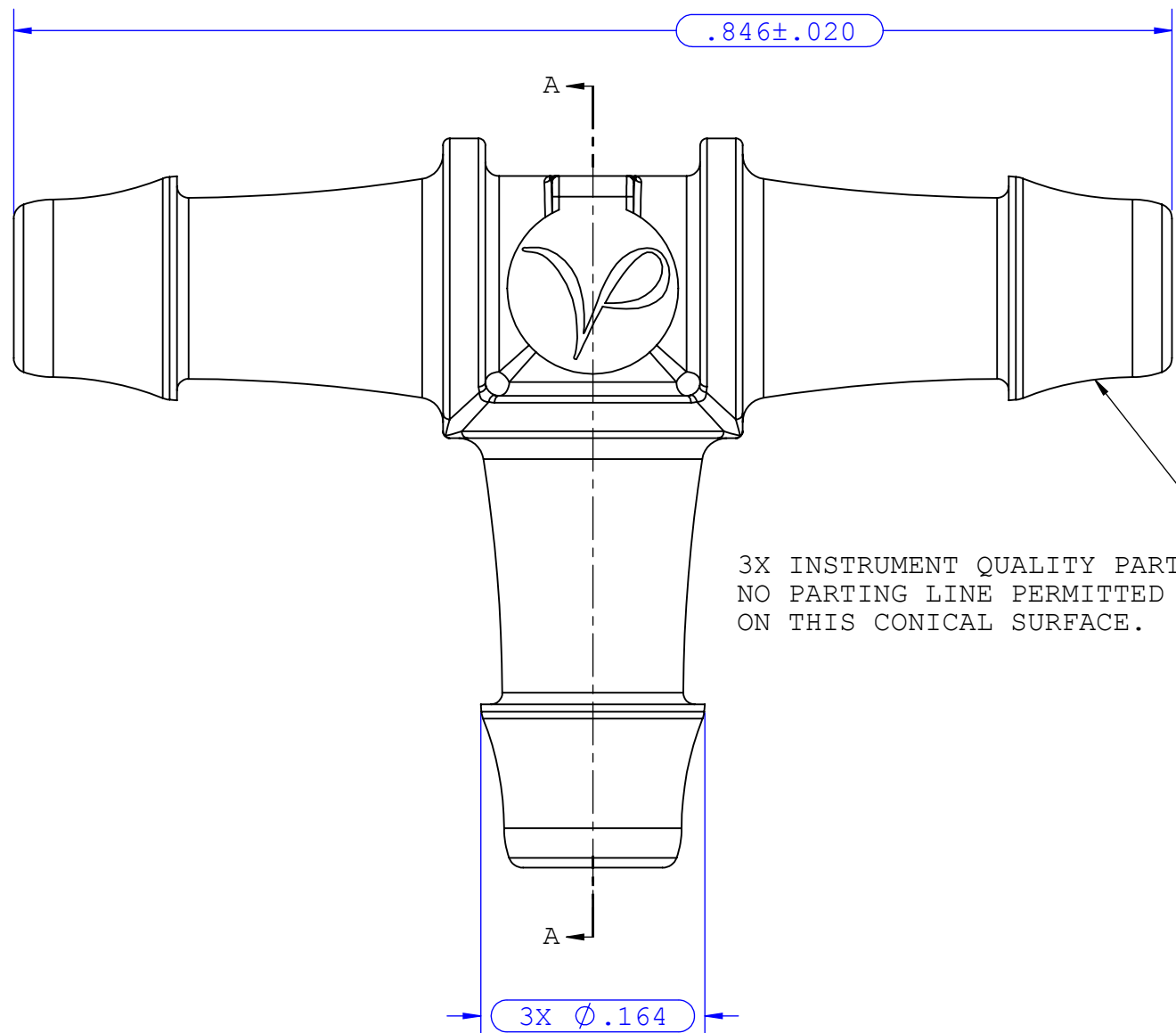

3X INSTRUMENT QUALITY PART.  
 NO PARTING LINE PERMITTED  
 ON THIS CONICAL SURFACE.

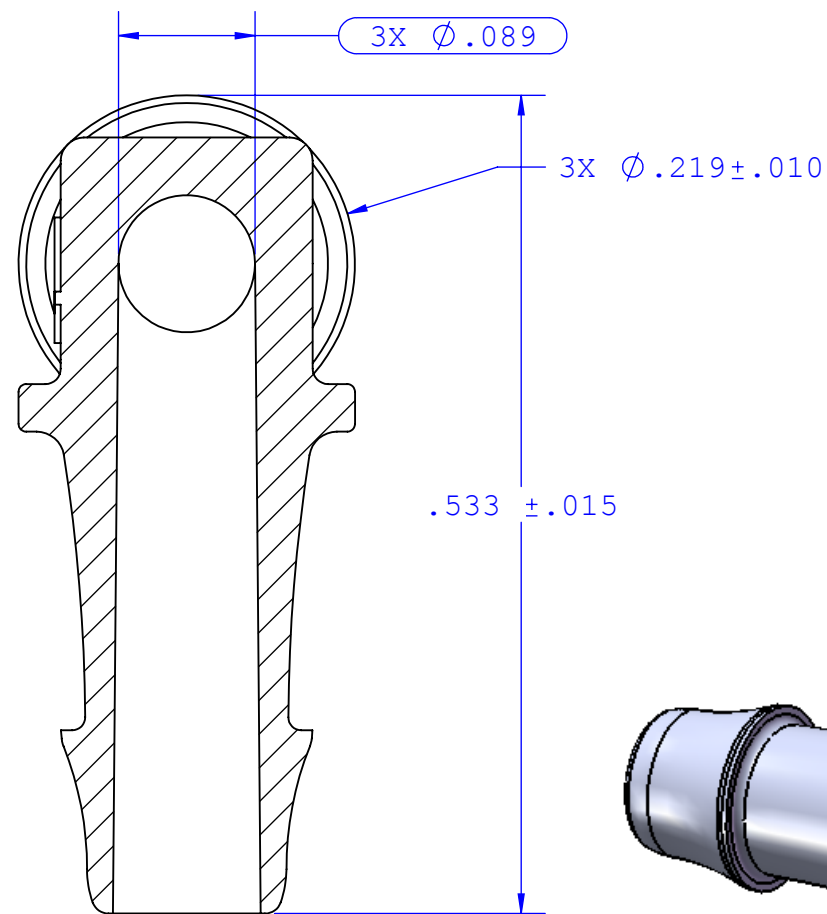

SECTION A-A

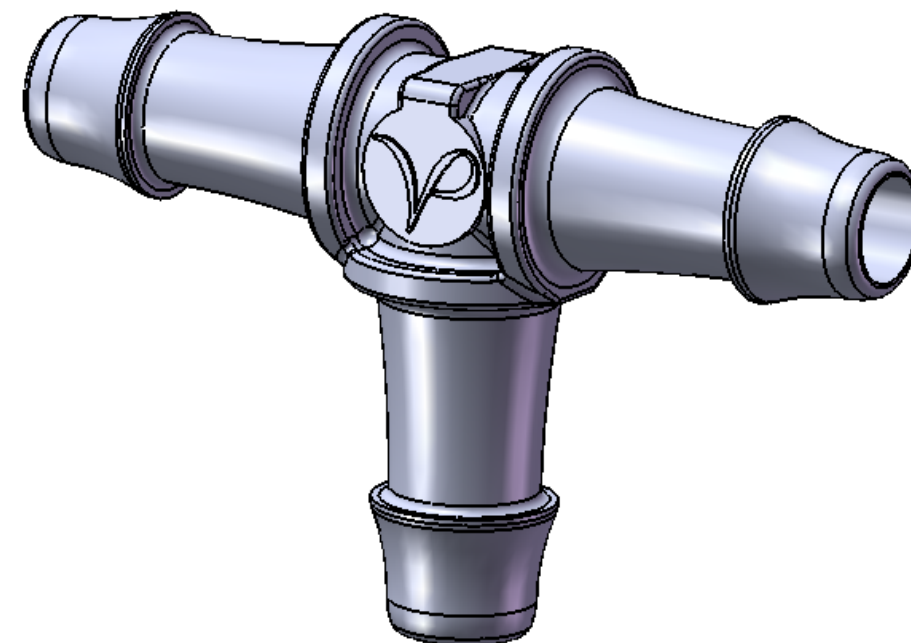

UNLESS OTHERWISE SPECIFIED DIMENSIONS ARE IN INCHES TOLERANCES ARE:		<b>VALUE PLASTICS, INC</b>			
FRACTIONS    DECIMAL    ANGULAR ±            .XX ±.01    ± 1° .XXX ±.005 .XXXX ±.001		PART NUMBER: T013			
DO NOT SCALE DRAWING		DESCRIPTION: Tee Connector with 500 Series Barbs, 1/8" (3.2 mm) ID Tubing			
DRAWN BY: Pete L.	DATE: 7/30/2008	SIZE: <b>B</b>	SCALE: NTS	VER: 	DWG. NO. 1013066
NEW PRODUCT DEVELOPMENT MGR: R. Narayanan		© 2008 VALUE PLASTICS, INC			REV A
SHEET: 1 OF 1					

**FOR REFERENCE ONLY**