

NOTES: FOR MORE DETAILED DRAWING SEE V.P.TOOLING STANDARDS
 DIMENSIONS MARKED  OR  ARE CONTROL DIMENSIONS

REVISIONS			
REV.	DESCRIPTION	DATE	APPROVED
A	INITIAL RELEASE	7/30/08	S.N.R

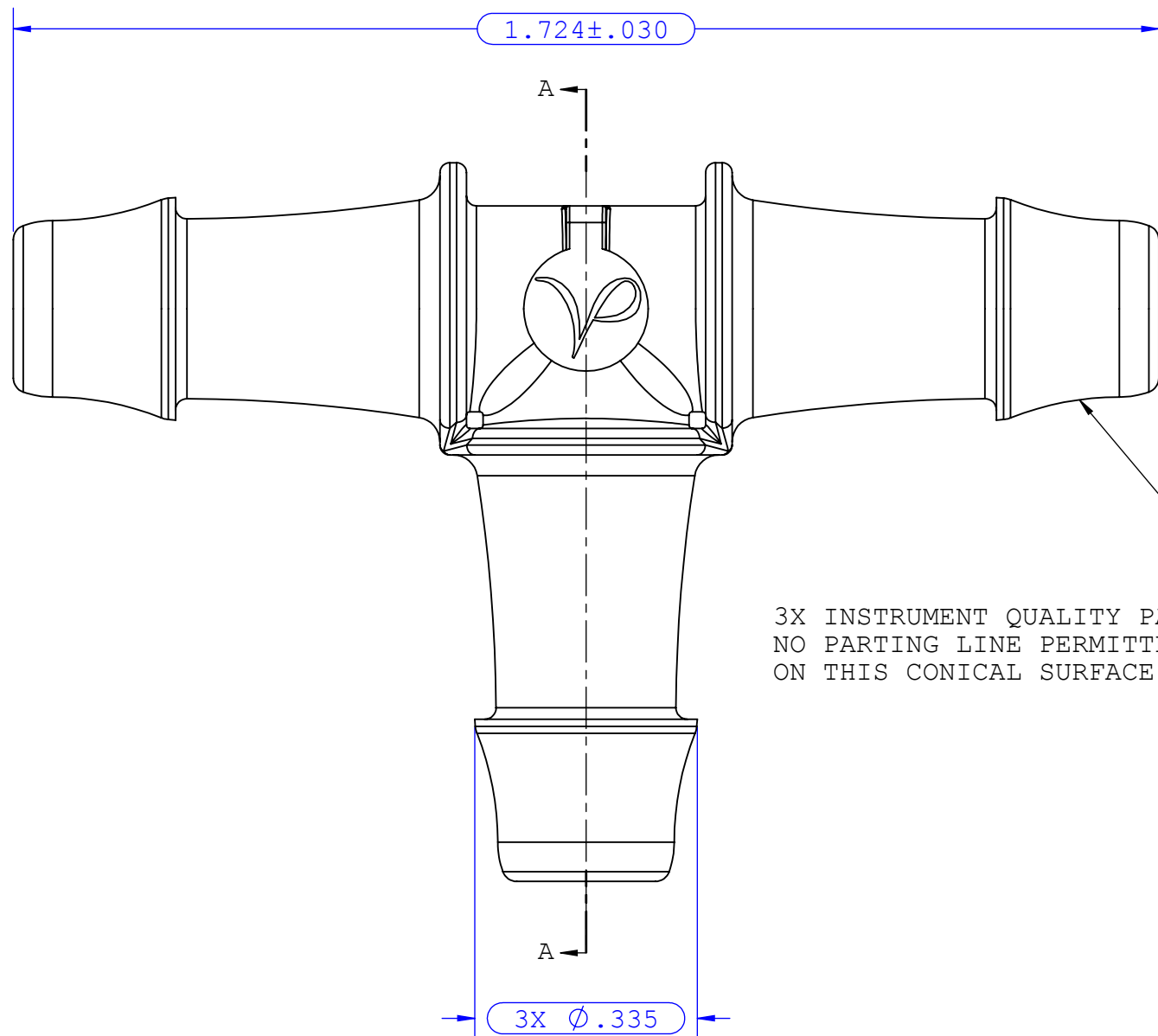

3X INSTRUMENT QUALITY PART.
 NO PARTING LINE PERMITTED
 ON THIS CONICAL SURFACE.

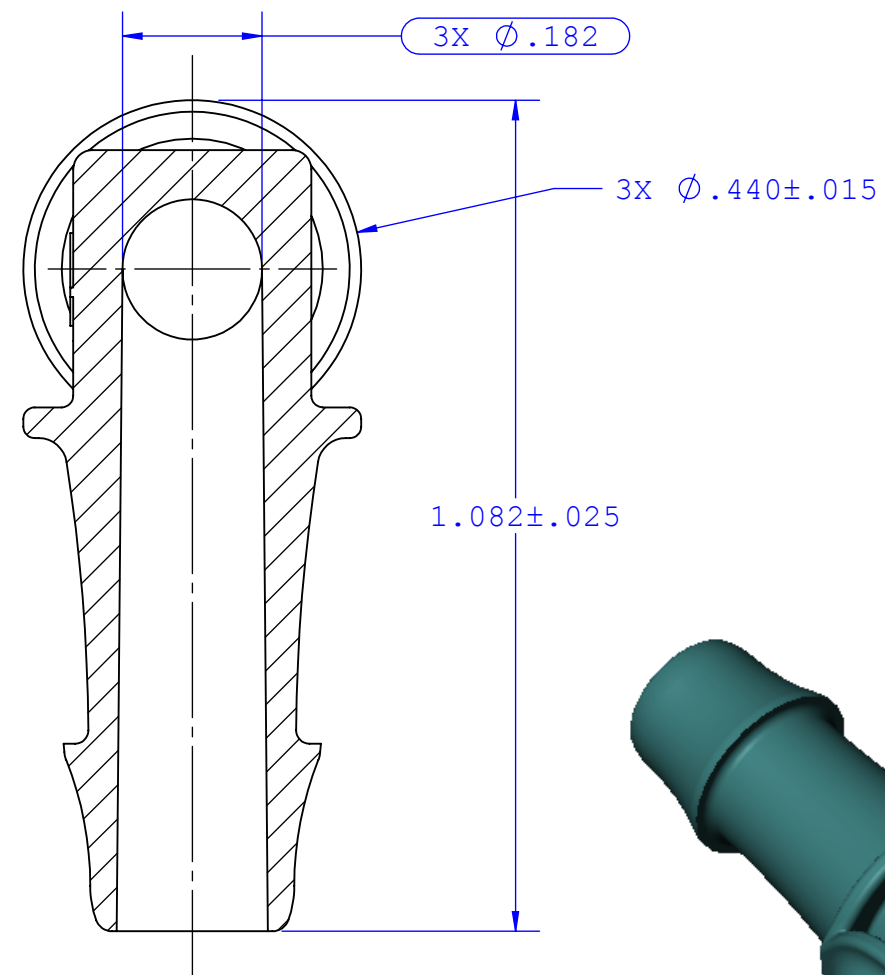

SECTION A-A

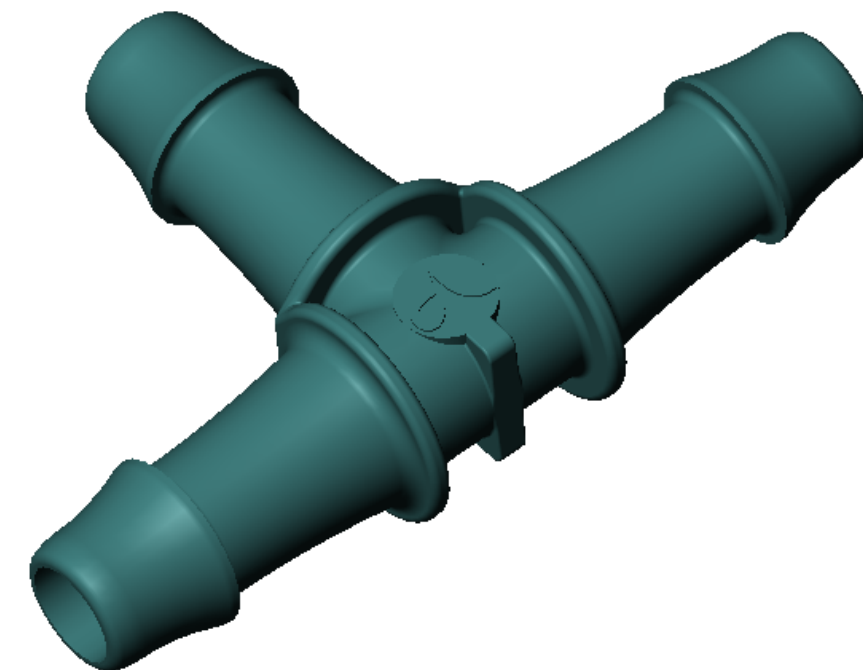

UNLESS OTHERWISE SPECIFIED DIMENSIONS ARE IN INCHES TOLERANCES ARE:		VALUE PLASTICS, INC			
FRACTIONS DECIMAL ANGULAR ± .XX ± .01 ± 1° .XXX ± .005 .XXXX ± .001		PART NUMBER: T055			
DO NOT SCALE DRAWING		DESCRIPTION: Tee Connector with 500 Series Barbs, 1/4" (6.4 mm) ID Tubing			
DRAWN BY: Pete L.	DATE: 7/30/2008	SIZE: B	SCALE: NTS	VER: 1013067	DWG. NO. 1013067
NEW PRODUCT DEVELOPMENT MGR: R. Narayanan		© 2008 VALUE PLASTICS, INC			REV A
				SHEET: 1 OF 1	

FOR REFERENCE ONLY