

NOTE: FOR MORE DETAILS SEE YOUR V.P. CUSTOMER SERVICE REP.

| REVISIONS | | | |
|-----------|------------------------|----------|----------|
| REV. | DESCRIPTION | DATE | APPROVED |
| A | INITIAL RELEASE | 12-19-02 | |
| B | CO 046 Drafting Update | 6-20-06 | Rick C. |

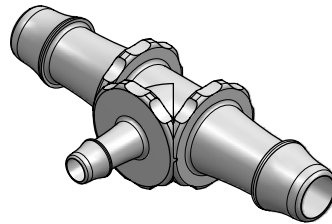
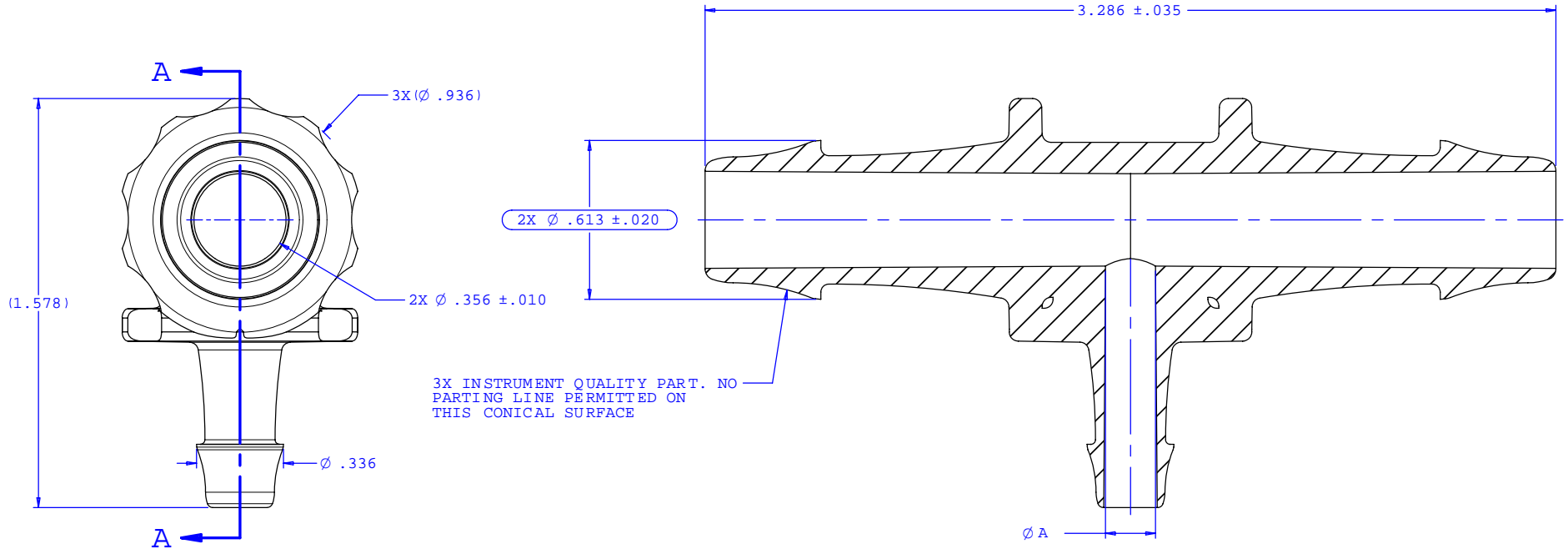

SECTION A-A

| Dimension | Material Specific Tolerances | | | | | | | |
|-----------|------------------------------|-------|------|------|------|------|-------------|------|
| | Acetal | Nylon | PP | ABS | PC | PVC | Polysulfone | J1A |
| A | .193 | .193 | .188 | .193 | .193 | .193 | .193 | .193 |
| B | | | | | | | | |
| C | | | | | | | | |
| D | | | | | | | | |
| E | | | | | | | | |
| F | | | | | | | | |

| | | | |
|---|---|--|---------------------------------|
| UNLESS OTHERWISE SPECIFIED DIMENSIONS ARE IN INCHES TOLERANCES ARE: | | VALUE PLASTICS, INC. | |
| FRACTIONS ± | DECIMALS .XX ±.01 .XXX ±.005 .XXXX ±.001 | ANGULAR ±1° | PART NUMBER: T080/055 |
| DO NOT SCALE DRAWING | | DESCRIPTION: Tee Reduction Connector with 500 Series Barbs, 1/2" (12.5 mm) and 1/4" (6.25 mm) ID Tubing | |
| DRAWN BY: Frank Lombardi 05-31-06 | DATE: | SIZE: B SCALE: NTS | DRAWING NUMBER: 1008927 |
| Engineer/Manager: Rick Cairns | | © 2006 VALUE PLASTICS, INC. | REV. B SHEET: 1 OF 1 |

FOR REFERENCE ONLY