

NOTE: FOR MORE DETAILS SEE YOUR V.P.CUSTOMER SERVICE REP.

REVISIONS			
REV.	DESCRIPTION	DATE	APPROVED
A	INITIAL RELEASE	12-20-02	
B	CO 046 Drafting Update	08-22-06	Rick C.
C	Changed OAL for PC to 3.311	09-19-07	Rick C.

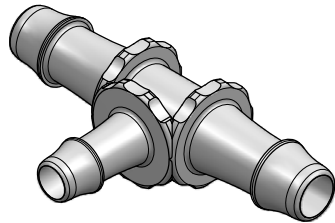
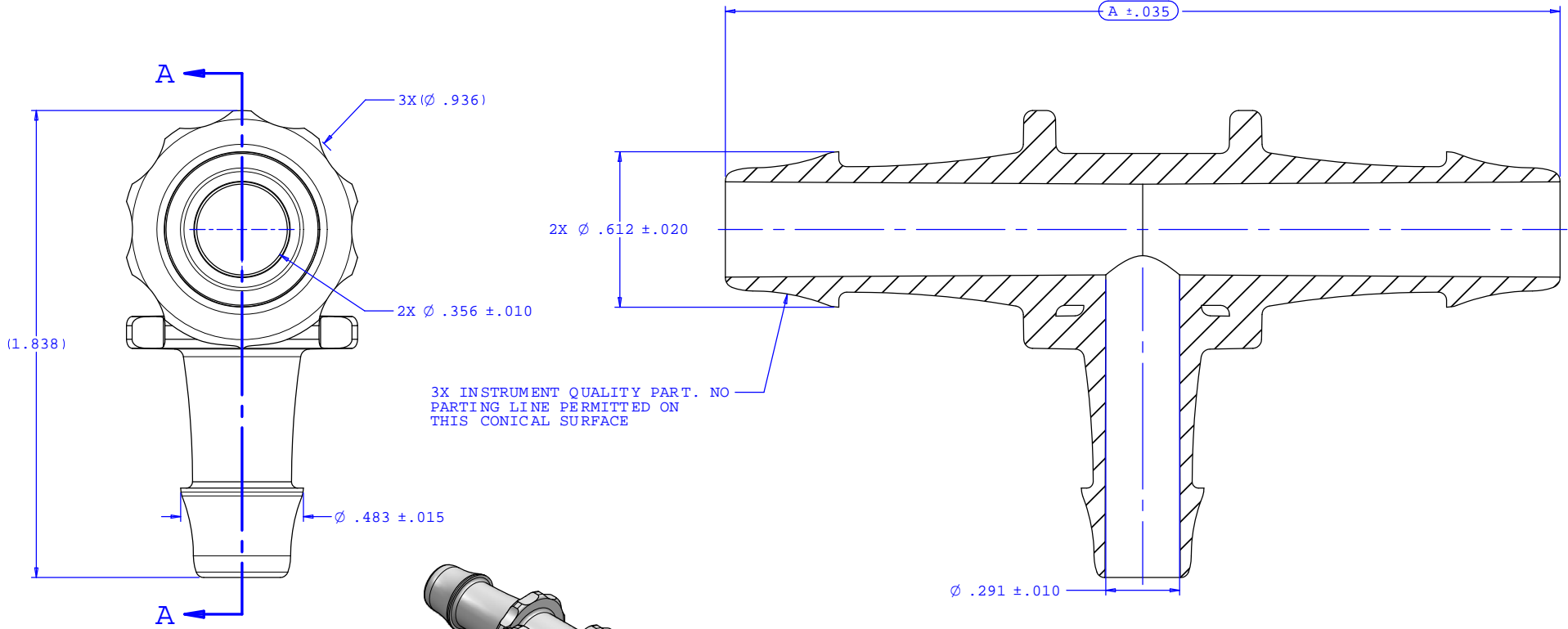

SECTION A-A

Dimension	Material Specific Tolerances							
	Acetal	Nylon	PP	ABS	PC	PVC	Polysulfone	J1A
A		3.286	3.286		3.311			
B								
C								
D								
E								
F								

UNLESS OTHERWISE SPECIFIED DIMENSIONS ARE IN INCHES TOLERANCES ARE:		VALUE PLASTICS, INC.	
FRACTIONS ±	DECIMALS .XX ±.01 .XXX ±.005 .XXXX ±.001	ANGULAR ±1°	PART NUMBER: T080/070
DO NOT SCALE DRAWING		DESCRIPTION: Tee Reduction Connector with 500 Series Barbs, 1/2" (12.5 mm) and 3/8" (9.5 mm) ID Tubing	
DRAWN BY: Frank Lombardi	DATE: 06-01-06	SIZE: B	SCALE: NTS
ENGINEER/ MANAGER: Rick Cairns		DRAWING NUMBER: 1008934	REV. C
© 2006 VALUE PLASTICS, INC.		SHEET: 1 OF 1	

FOR REFERENCE ONLY