

NOTE: FOR MORE DETAILS SEE YOUR V.P. CUSTOMER SERVICE REP.
 NOTE: CUSTOM GAGES ARE USED TO VERIFY TSC2 TAPER AND TSC2 THREAD

REVISIONS			
REV.	DESCRIPTION	DATE	APPROVED
A	INITIAL RELEASE	10-16-06	Rick C.

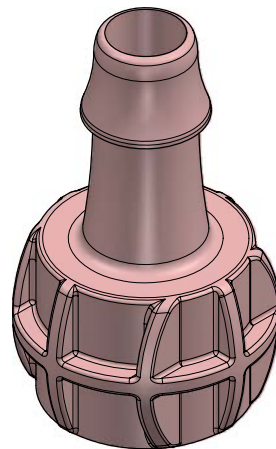
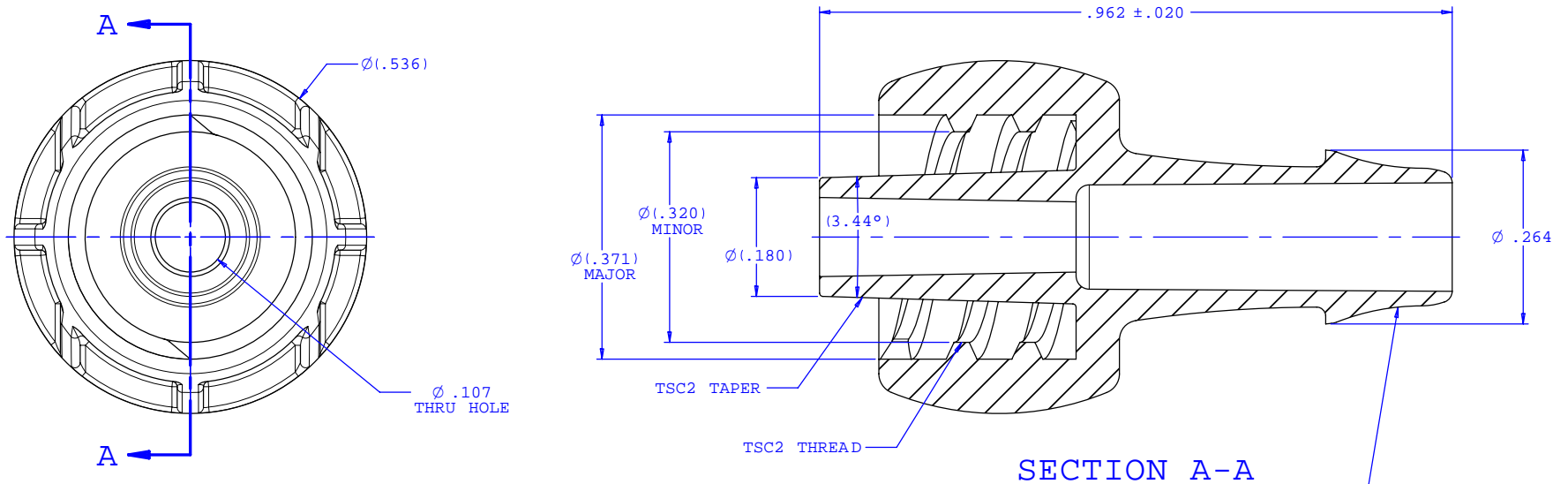

UNLESS OTHERWISE SPECIFIED DIMENSIONS ARE IN INCHES TOLERANCES ARE:		VALUE PLASTICS, INC.	
FRACTIONS ±	DECIMALS .XX ±.01 .XXX ±.005 .XXXX ±.001	ANGULAR ±1°	PART NUMBER: TSC2M035
DO NOT SCALE DRAWING		DESCRIPTION: Male Locking Taper Fitting to 500 Series Barb, 3/16" (4.75 mm) ID Tubing	
DRAWN BY: Frank Lombardi	DATE: 10-05-06	SIZE: B	SCALE: NTS
Engineer/Manager: Rick Cairns		DRAWING NUMBER: 1009606	REV. A
		© 2005 VALUE PLASTICS, INC.	SHEET: 1 OF 1

FOR REFERENCE ONLY