

NOTE: FOR MORE DETAILS SEE YOUR V.P.CUSTOMER SERVICE REP.

REVISIONS			
REV.	DESCRIPTION	DATE	APPROVED
A	INITIAL RELEASE	01-02-98	
B	CO 046 DRAFTING UPDATE	Rick C.	06/02/07

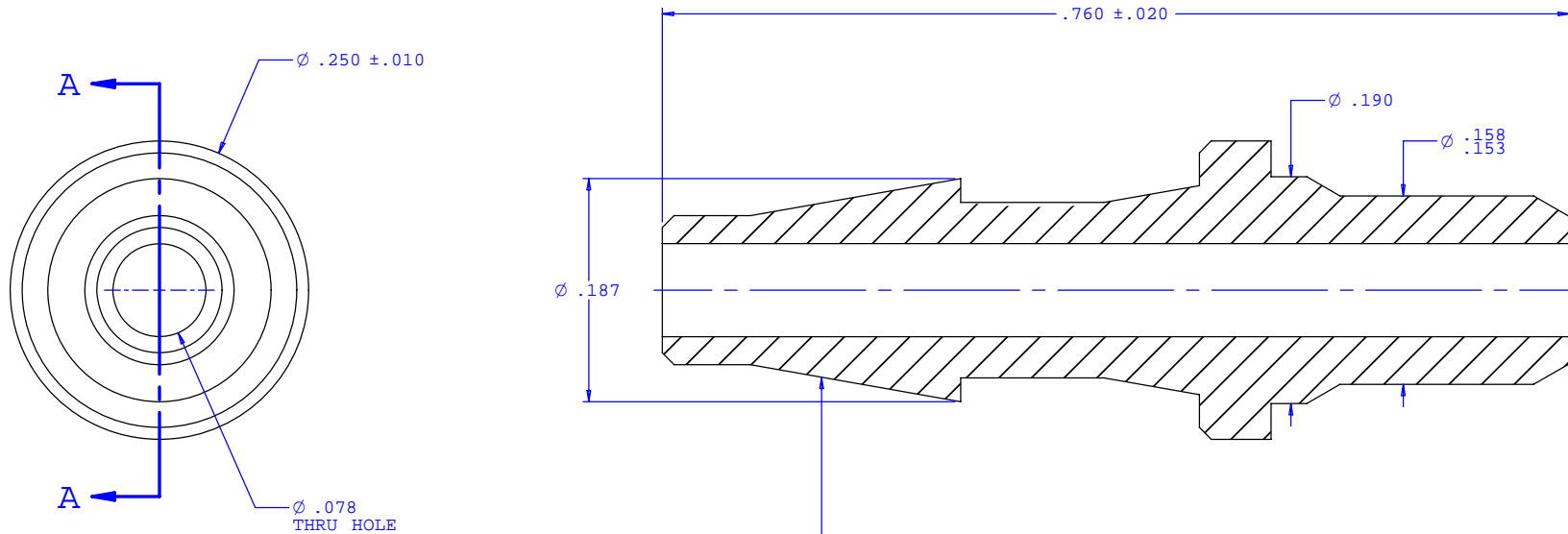

SECTION A-A

INSTRUMENT QUALITY PART. NO PARTING LINE ALLOWED ON THIS CONICAL SURFACE.

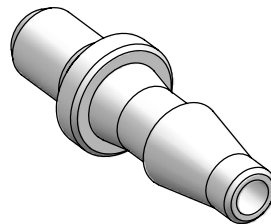

UNLESS OTHERWISE SPECIFIED DIMENSIONS ARE IN INCHES TOLERANCES ARE:		VALUE PLASTICS, INC.	
FRACTIONS ±	DECIMALS .XX ±.01 .XXX ±.005 .XXXX ±.001	ANGULAR ±1°	PART NUMBER: U30
DO NOT SCALE DRAWING		DESCRIPTION: Ultrasonically Weldable Fitting to Classic Series Barb, 1/8" (3 mm) ID Tubing	
DRAWN BY: Randy Sakurada	DATE: 01-23-07	SIZE: B SCALE: NTS	DRAWING NUMBER: 1010104 REV. B
Engineer/Manager: Rick Cairns		© 2007 VALUE PLASTICS, INC. SHEET: 1 OF 1	

FOR REFERENCE ONLY