

NOTES: FOR ADDITIONAL DETAILS, PLEASE CONTACT VP CUSTOMER SERVICE

REVISIONS			
REV.	DESCRIPTION	DATE	APPROVED
A	INITIAL RELEASE	02/19/09	Rick C.

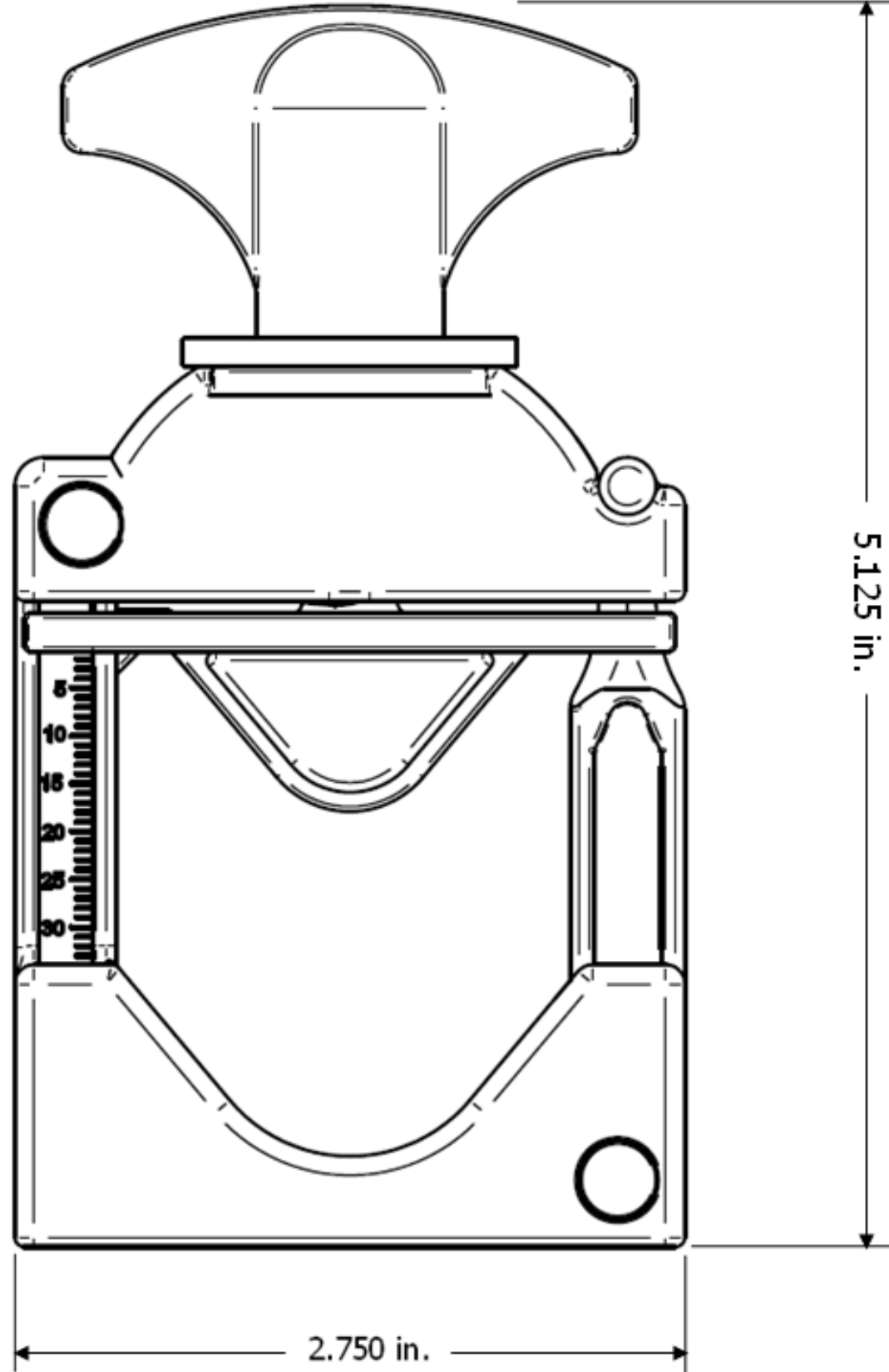

UNLESS OTHERWISE SPECIFIED DIMENSIONS ARE IN INCHES TOLERANCES ARE:		VALUE PLASTICS, INC			
FRACTIONS DECIMAL ANGULAR ± .XX ±.01 ± 1° .XXX ±.005 .XXXX ±.001		PART NUMBER: VBV1000NW			
DO NOT SCALE DRAWING		DESCRIPTION: Pinch Valve 1/2 to 1" Glass Reinforced White Nylon			
DRAWN BY: MICHELE SCHENK	DATE: 2/19/2009	SIZE: B	SCALE: NTS	VER: 	DWG. NO. 1014678
ENGINEERING MGR: Rick Cairns		© 2009 VALUE PLASTICS, INC			REV A
SHEET: 1 OF 1					

FOR REFERENCE ONLY