

NOTES: FOR ADDITIONAL DETAILS, PLEASE CONTACT VP CUSTOMER SERVICE

REVISIONS			
REV.	DESCRIPTION	DATE	APPROVED
A	Initial Release	7-29-10	R. Cairns
B	ECO 235: Material Change	7-26-12	R. Cairns

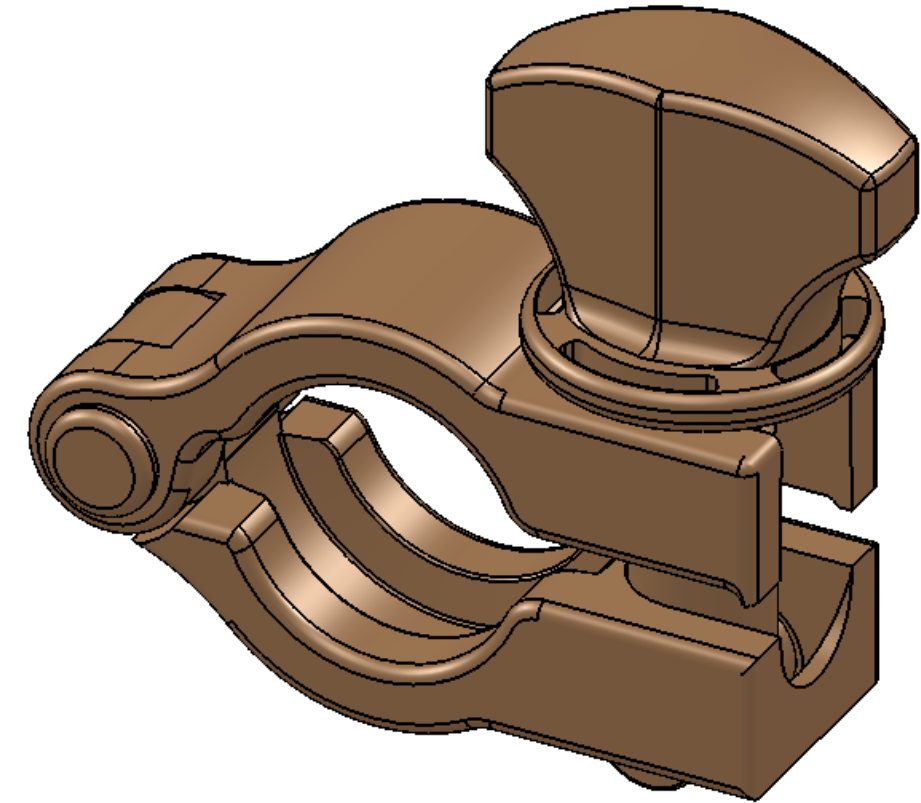
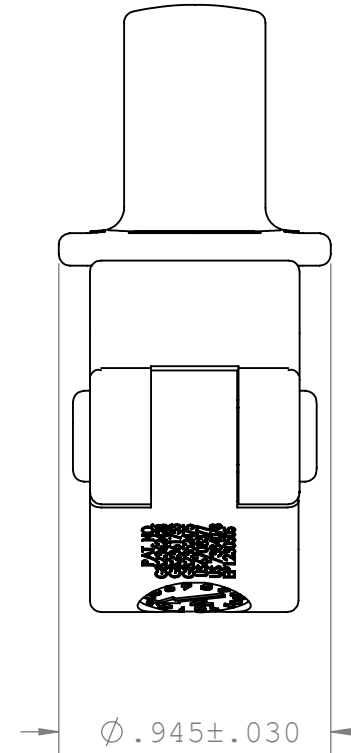
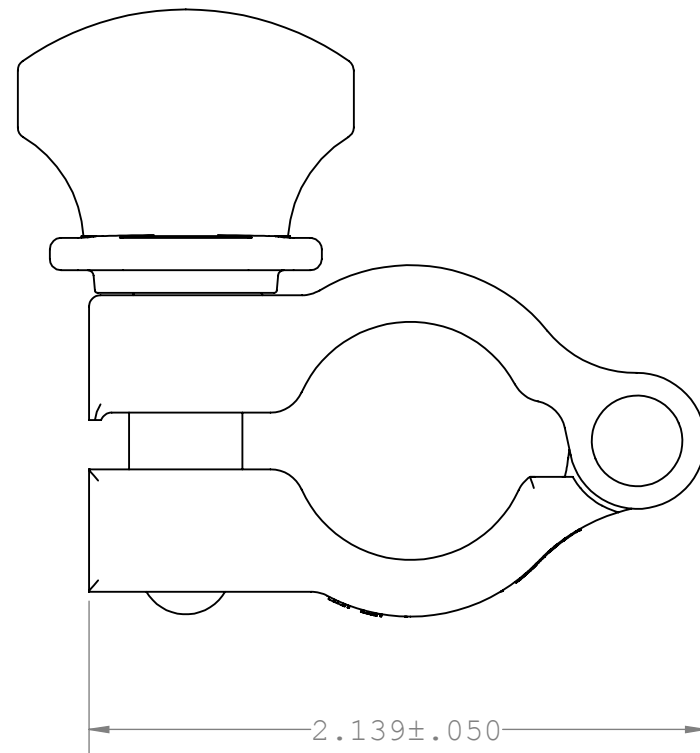

UNLESS OTHERWISE SPECIFIED DIMENSIONS ARE IN INCHES TOLERANCES ARE:		VALUE PLASTICS, INC			
FRACTIONS DECIMAL ANGULAR ± .XX ±.01 ± 1° .XXX ±.005 .XXXX ±.001 DO NOT SCALE DRAWING		PART NUMBER: VNG075WHT			
		DESCRIPTION: Clamp, Mini Flange, ½" (12.7 mm) to 3/4" (19.0 mm), Glass Reinforced White Nylon			
DRAWN BY: Marcus Kincaid	DATE: 9/11/2012	SIZE: B	SCALE: NTS	VER:	DWG. NO. 1018290
MANAGER: R. Cairns		© 2010 VALUE PLASTICS, INC			REV B
				SHEET: 1 OF 1	

FOR REFERENCE ONLY