

NOTE: FOR MORE DETAILS SEE YOUR V.P.CUSTOMER SERVICE REP.

REVISIONS			
REV.	DESCRIPTION	DATE	APPROVED
A	INITIAL RELEASE	04-17-98	
B	CO 031 Drafting Update	02-20-06	Rick C.

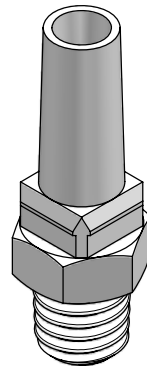
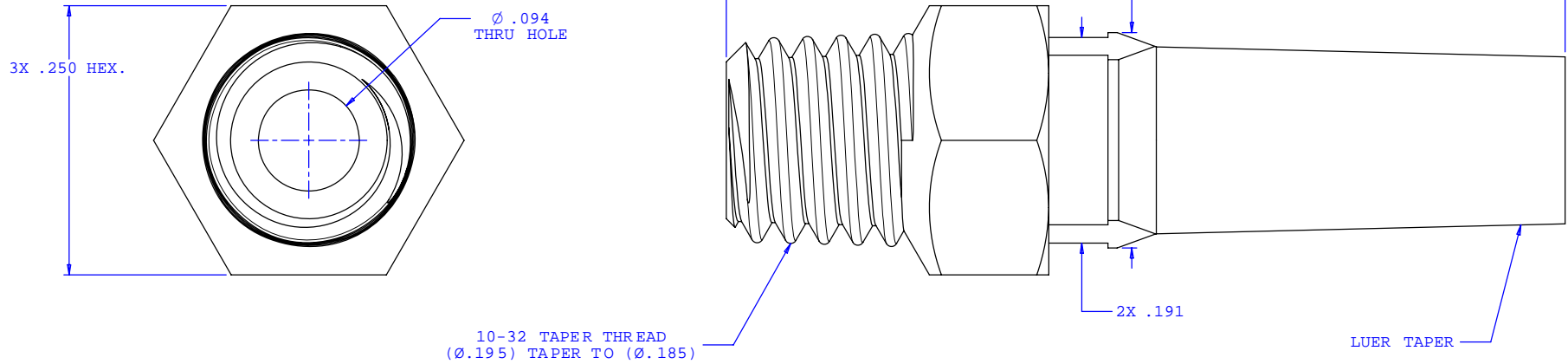

UNLESS OTHERWISE SPECIFIED DIMENSIONS ARE IN INCHES TOLERANCES ARE:		VALUE PLASTICS, INC.	
FRACTIONS ±	DECIMALS .XX ±.01 .XXX ±.005 .XXXX ±.001	ANGULAR ±1°	PART NUMBER: XMTL
DO NOT SCALE DRAWING		DESCRIPTION: MALE LUER TO 10-32 UNF SPECIAL	
DRAWN BY: Frank Lombardi	DATE: 10-03-05	SIZE: B	SCALE: NTS
ENGINEER/ MANAGER: Rick Cairns		DRAWING NUMBER: 1007692	REV. B
© 2005 VALUE PLASTICS, INC.		SHEET: 1 OF 1	

FOR REFERENCE ONLY