

NOTE: FOR MORE DETAILS SEE YOUR V.P.CUSTOMER SERVICE REP.

| REVISIONS | | | |
|-----------|------------------------|----------|----------|
| REV. | DESCRIPTION | DATE | APPROVED |
| A | INITIAL RELEASE | 08-20-98 | |
| B | CO 031 Drafting Update | 02-20-06 | Rick C. |

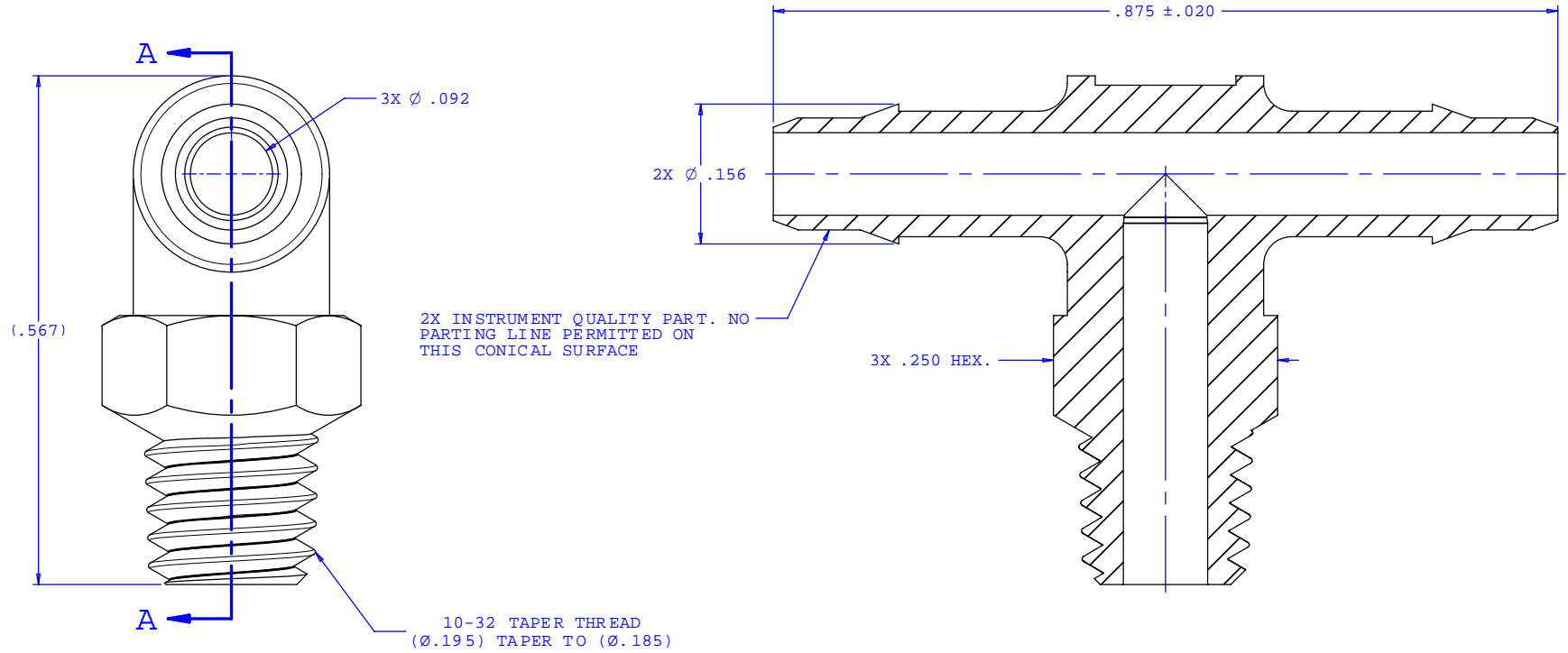

SECTION A-A

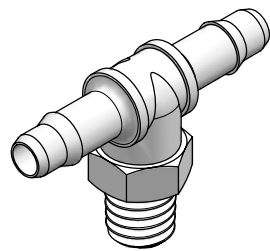

| | | | |
|---|---|---|---------------------------|
| UNLESS OTHERWISE SPECIFIED DIMENSIONS ARE IN INCHES TOLERANCES ARE: | | VALUE PLASTICS, INC. | |
| FRACTIONS ± | DECIMALS .XX ±.01 .XXX ±.005 .XXXX ±.001 | ANGULAR ±1° | PART NUMBER: XT430 |
| DO NOT SCALE DRAWING | | DESCRIPTION: 10-32 Special Tapered Thread Tee with 1/4" Hex to 400 Series Barb, 1/8" (3 mm) ID Tubing | |
| DRAWN BY: Frank Lombardi | DATE: 09-30-05 | SIZE: B | SCALE: NTS |
| ENGINEER/ MANAGER: Rick Cairns | | DRAWING NUMBER: 1007683 | REV. B |
| © 2005 VALUE PLASTICS, INC. | | | SHEET: 1 OF 1 |

FOR REFERENCE ONLY