

NOTES: FOR MORE DETAILED DRAWING SEE V.P.TOOLING STANDARDS
 DIMENSIONS MARKED OR ARE CONTROL DIMENSIONS

REVISIONS			
REV.	DESCRIPTION	DATE	APPROVED
A	INITIAL RELEASE	7-29-08	S.N.R

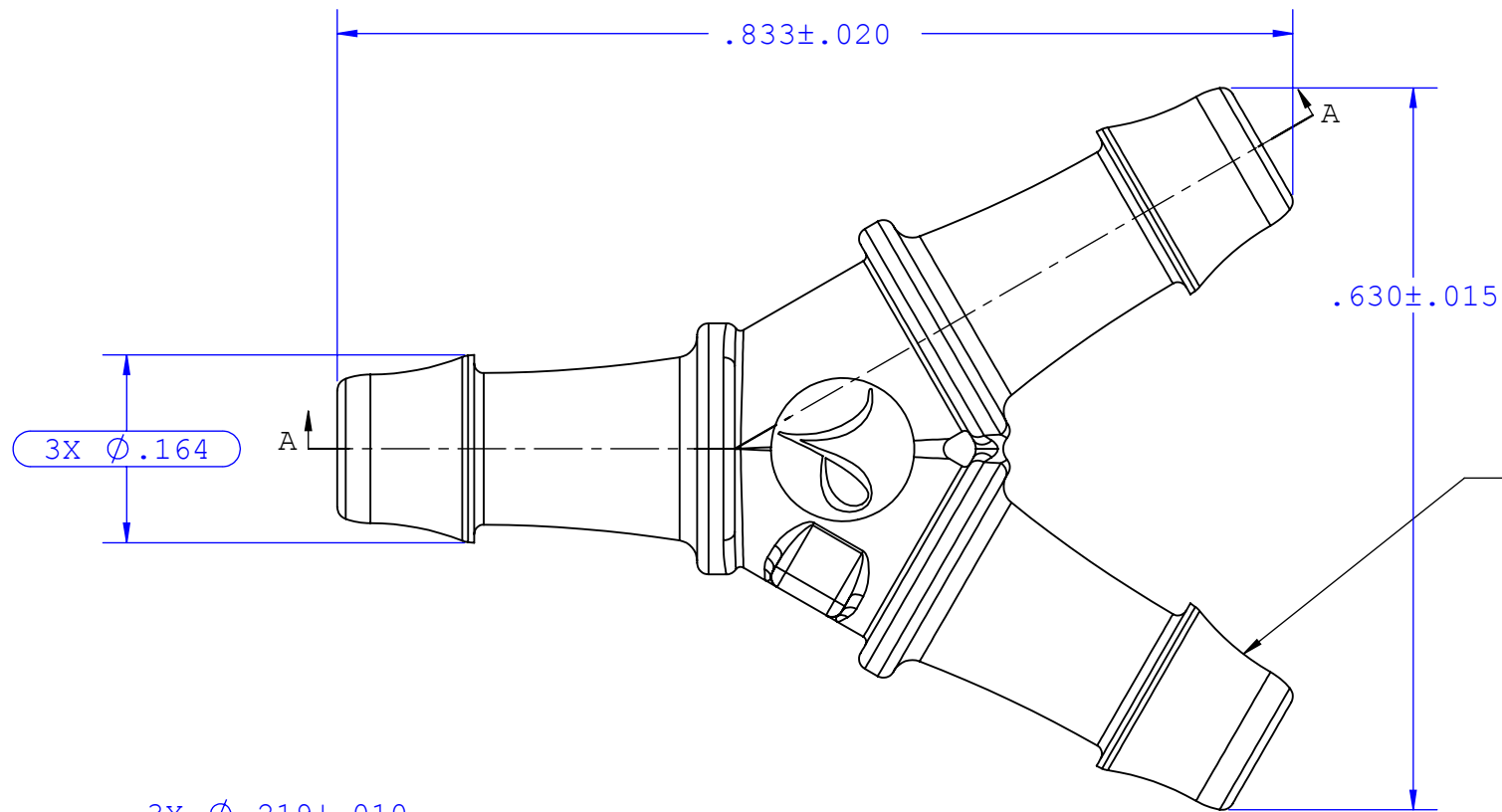

3X INSTRUMENT QUALITY PART. NO PARTING LINE PERMITTED ON THIS CONICAL SURFACE.

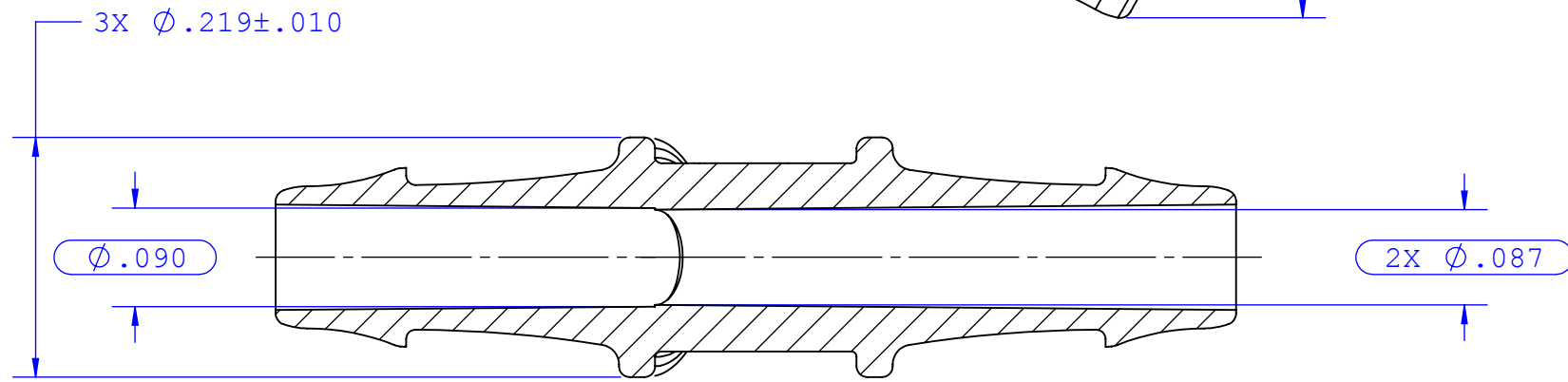

SECTION A-A

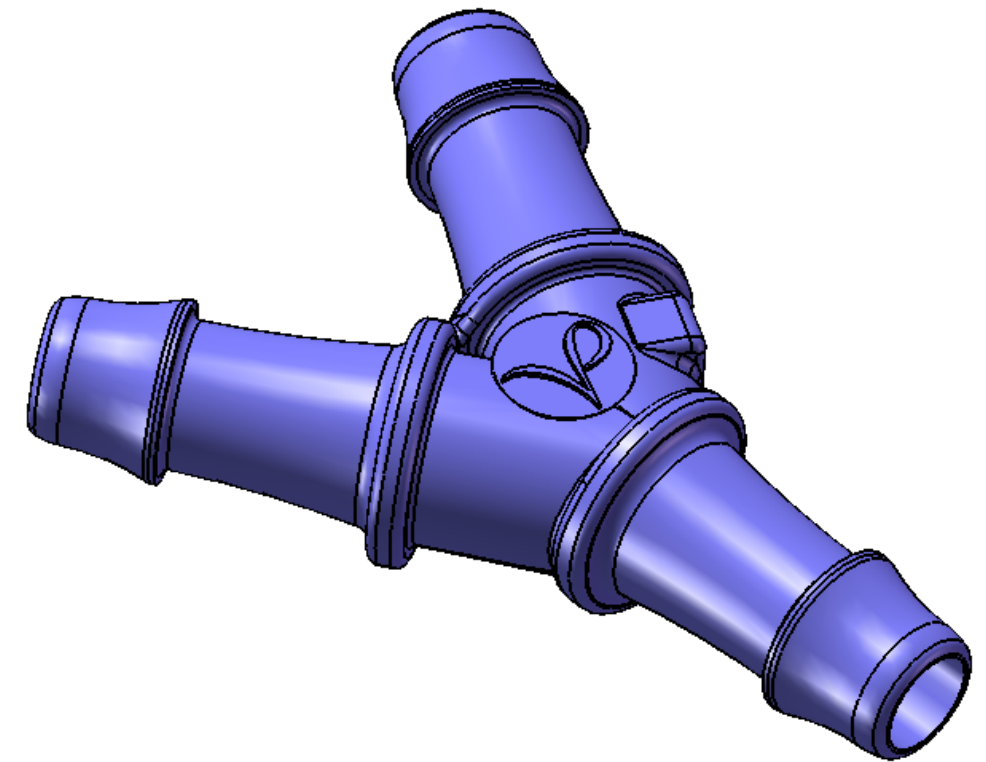

UNLESS OTHERWISE SPECIFIED DIMENSIONS ARE IN INCHES TOLERANCES ARE:		VALUE PLASTICS, INC			
FRACTIONS DECIMAL ANGULAR ± .XX ±.01 ± 1° .XXX ±.005 .XXXX ±.001		PART NUMBER: Y013			
DO NOT SCALE DRAWING		DESCRIPTION: Y Connector with 500 Series Barbs, 1/8" (3.2 mm) ID Tubing			
DRAWN BY: Pete L.	DATE: 8/7/2008	SIZE: B	SCALE: NTS	VER: 	DWG. NO. 1013063
NEW PRODUCT DEVELOPMENT MGR: R. Narayanan		© 2008 VALUE PLASTICS, INC			REV A
SHEET: 1 OF 1					

FOR REFERENCE ONLY